

i) Floor Max - Floor Max functions as the maximum floor temperature in Dual mode, and will override the room temperature.

ii) Floor Min - Floor Min functions as the minimum floor temperature in Dual mode, and will override the room temperature.

7. The Control must provide the following operation mode, within the Cooling Thermostat mode:

a. **Room Mode** – Sensor(s) providing feedback for the specific room or zone being controlled by the thermostat.

Sensor 1 - Set the external sensor as None, Floor, Room, Outdoor or Room Average.

i) None - No external sensor is connected to the thermostat.

ii) Floor - The external sensor is used to display floor temperature.

iii) Room - The external sensor is used to control the room temperature.

iv) Outdoor - The external sensor is used to display outdoor temperature.

v) Room Average - This setting averages the external sensor and internal sensor to control the room temperature.

8. The Control must have a detachable face with terminal blocks integrated to thermostat back plate.

9. The Control must be capable of Proportional, Integral and Derivative (PID) control modes for responding to load conditions through feedback sensors (integrated and/or external sensor) when operating in Heating Thermostat mode.

10. The Control programming must have a selectable option to display less information to the end user.

11. The Control must be ETL approved.

Part 2: Acceptable Products

1. HBX THM-0100 Control



Part 3: Physical Dimensions

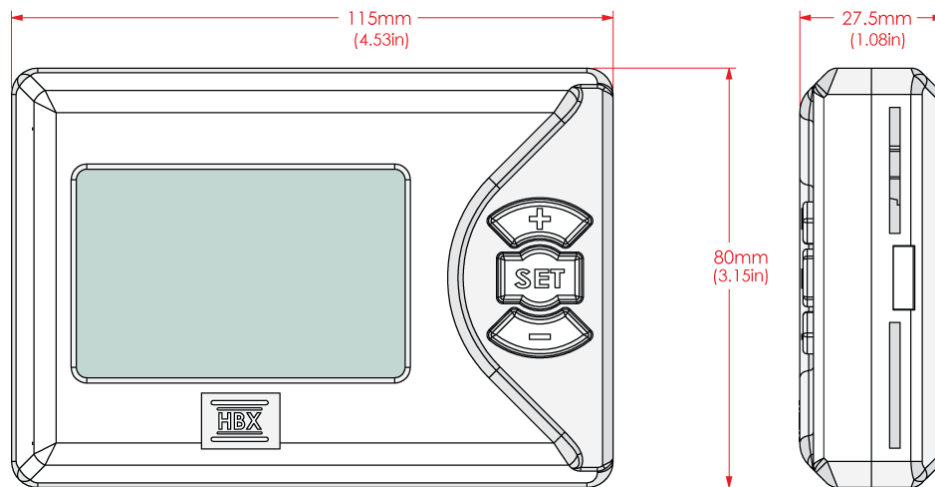

Part 4: Technical Data, Main Parts & Labels

Inputs/Outputs:

- 1 x Thermistor Input (10K Ohm)
- 1 x Relay Dry Contact (24VAC, 2A) Output

Power supply:

10-24V, AC or DC

Supplied Parts:

- 1 x HBX 029-0032 – 10K Ohm Thermistor, 10' lead wire

Dimensions:

4.53" x 3.15" x 1.08" (115mm x 80mm x 27.5mm)

ETL Listings:

- Meets CSA C22.2 No. 24
- Meets UL Standard 873
- ETL Control No. 3068143

Storage:

50°F to 104°F (10°C to 40°C)



Pin Out / Terminal Block Labels:

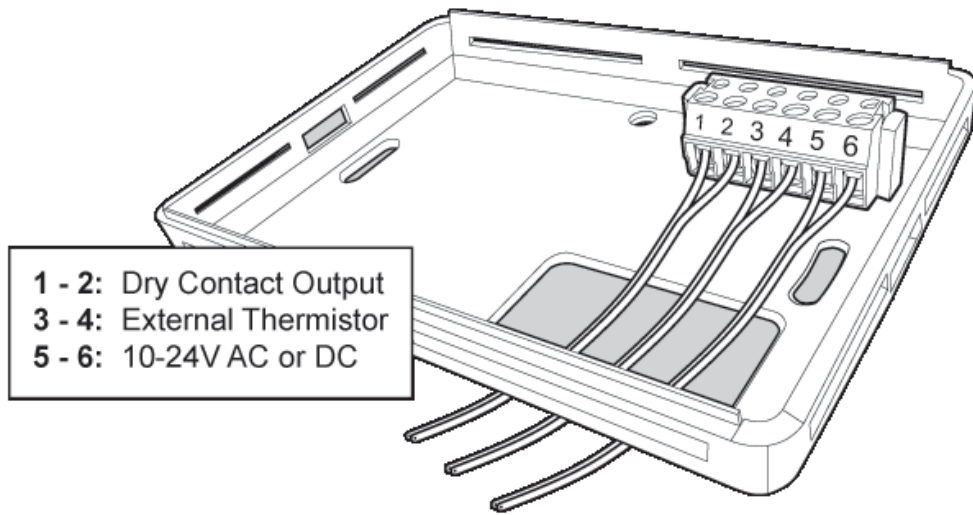

Part 5: HBX Sensor Temperature Conversion / Resistance Table

Celsius	Fahrenheit	Ohms	Celsius	Fahrenheit	Ohms	Celsius	Fahrenheit	Ohms
-30	-22	177,000	15	59	15,714	60	140	2,488
-29	-20.2	166,342	16	60.8	15,000	61	141.8	2,400
-28	-18.4	156,404	17	62.6	14,323	62	143.6	2,315
-27	-16.6	147,134	18	64.4	13,681	63	145.4	2,235
-26	-14.8	138,482	19	66.2	13,071	64	147.2	2,157
-25	-13	130,402	20	68	12,493	65	149	2,083
-24	-11.2	122,807	21	69.8	11,942	66	150.8	2,011
-23	-9.4	115,710	22	71.6	11,418	67	152.6	1,943
-22	-7.6	109,075	23	73.4	10,921	68	154.4	1,876
-21	-5.8	102,868	24	75.2	10,449	69	156.2	1,813
-20	-4	97,060	25	77	10,000	70	158	1,752
-19	-2.2	91,588	26	78.8	9,571	71	159.8	1,693
-18	-0.4	86,463	27	80.6	9,164	72	161.6	1,637
-17	1.4	81,662	28	82.4	8,776	73	163.4	1,582
-16	3.2	77,162	29	84.2	8,407	74	165.2	1,530
-15	5	72,940	30	86	8,056	75	167	1,480
-14	6.8	68,957	31	87.8	7,720	76	168.8	1,431
-13	8.6	65,219	32	89.6	7,401	77	170.6	1,385
-12	10.4	61,711	33	91.4	7,096	78	172.4	1,340
-11	12.2	58,415	34	93.2	6,806	79	174.2	1,297
-10	14	55,319	35	95	6,530	80	176	1,255
-9	15.8	52,392	36	96.8	6,266	81	177.8	1,215
-8	17.6	49,640	37	98.6	6,014	82	179.6	1,177
-7	19.4	47,052	38	100.4	5,774	83	181.4	1,140
-6	21.2	44,617	39	102.2	5,546	84	183.2	1,104
-5	23	42,324	40	104	5,327	85	185	1,070
-4	24.8	40,153	41	105.8	5,117	86	186.8	1,037
-3	26.6	38,109	42	107.6	4,918	87	188.6	1,005
-2	28.4	36,182	43	109.4	4,727	88	190.4	974
-1	30.2	34,367	44	111.2	4,544	89	192.2	944
0	32	32,654	45	113	4,370	90	194	915
1	33.8	31,030	46	114.8	4,203	91	195.8	889
2	35.6	29,498	47	116.6	4,042	92	197.6	861
3	37.4	28,052	48	118.4	3,889	93	199.4	836
4	39.2	26,686	49	120.2	3,743	94	201.2	811
5	41	25,396	50	122	3,603	95	203	787
6	42.8	24,171	51	123.8	3,469	96	204.8	764
7	44.6	23,013	52	125.6	3,340	97	206.6	742
8	46.4	21,913	53	127.4	3,217	98	208.4	721
9	48.2	20,883	54	129.2	3,099	99	210.2	700
10	50	19,903	55	131	2,986	100	212	680
11	51.8	18,972	56	132.8	2,877	101	213.8	661
12	53.6	18,090	57	134.6	2,774	102	215.6	643
13	55.4	17,255	58	136.4	2,675	103	217.4	626
14	57.2	16,464	59	138.2	2,579	104	219.2	609

