

Installation Manual
Central Processing Unit 0550
Version 2.06.1

The HBX logo consists of the letters 'HBX' in a bold, black, sans-serif font. The letters are centered between two horizontal red bars, one above and one below. The background of the entire page features a pattern of thin, light-colored lines that create a sense of depth and movement, with a darker, more solid area on the left side.

HBX

Boiler Staging • Mixing • Differential Setpoint • Pump Sequencer • Dual Setpoint

CPU-0550

HBX Control Systems Inc.



TABLE OF CONTENTS

Introduction 1-3

Safety Symbols & Warnings 1

Receipt & Inspection 1

Description 2

Technical Data and Dimensions 3

Wiring & Installation 4

Wiring 4

Installation 4

Programming CPU-0550 5-23

Navigating the CPU-0550 5

Control Mode..... 5

Setup Menu..... 6

Boiler Control Programming 7-13

Mixing Control Programming 14-21

Differential Setpoint Programming 22-24

Pump Sequencer 25-28

Dual Setpoint..... 29-32

Connecting to a Wireless Network (iOS)..... 33-34

Connecting to a Wireless Network (Android)..... 35-36

Sample Wiring and Diagrams 37-44

Troubleshooting Guide..... 45-47

Warranty Information 48

Table of Contents

HBX CPU-0550 HYDRONIC CONTROLLER

INTRODUCTION

This manual will help with the installation, parameter setting, troubleshooting and general maintenance requirements for the controller. To guarantee the safe and reliable operation of this control, you must first read this manual in detail and take particular note to any and all warnings or caution directives prior to connecting to AC power.

Please consult and install the heating appliance in accordance with manufacture's recommendations.

QR CODE

Each CPU-0550 is labeled with a QR code, which when scanned will link to a digital version of this manual. If this manual is ever lost or damaged, simply scan this with a compatible device to download the latest manual version.

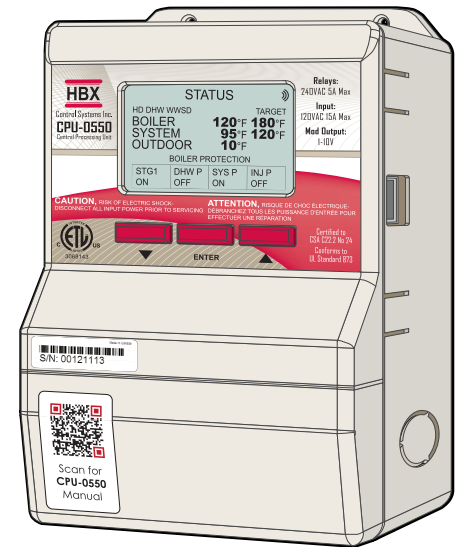

WARNING: This product can expose you to chemicals including lead, which is known to the State of California to cause cancer and birth defects or other reproductive harm. For more information go to www.P65Warnings.ca.gov.

SAFETY SYMBOLS & WARNINGS



Extreme Hazard

This action poses a serious threat that could result in personal injury or death, as well as permanent damage to the equipment. Proceed with caution.



Moderate Hazard

This action may cause personal injury or have adverse effects on the installation process if handled incorrectly.



Disconnect Power Source

The presence of low voltage(24VAC) or high voltage(120VAC) could result in personal injury or permanent damage to components or equipment.



Point of Interest

This point clarifies pertinent information, or brings your attention to an action that may have adverse effects on the installation process.



Drawing Reference

Refer to the specified electrical or mechanical drawing at the back of the manual.



Only suitably qualified individuals with formal training in electrical and Hydronic controls should attempt the installation of this equipment. Incorrect wiring and installation will affect the warranty provided with this unit. Wiring must be completed in accordance with the codes and practices applicable to the jurisdiction for the actual installation.



Use only copper conductor supply wire suitable for at least 105 °C



The HBX CPU-0550 is a microprocessor based controller and as such is not to be regarded as a safety (limit) control. Please consult and install the heating or cooling appliance in accordance with the manufacturer's recommendations.

RECEIPT & INSPECTION

After receiving, inspect the unit for any possible physical damage that may have occurred during transportation.

After unpacking the unit make sure the box contains:

- 1 x Remote Outdoor sensor (Part #OUT-0100)
- 2 x Universal sensors (Part #029-0022)
- 1 x Terminal Screwdriver (2.5mm)
- 2 x Cable ties
- 1 x Manual

HBX CPU-0550 HYDRONIC CONTROLLER

DESCRIPTION

The CPU-0550 is designed to be a stand-alone Outdoor Reset Control device. The purpose and function of the CPU-0550 is to provide control for multiple applications. The applications are selectable through push button operation on the programming interface and consist of Boiler, Mixing, Differential Setpoint control or Pump Sequencer.

Boiler Control

The use of the CPU-0550 as a Boiler Control allows the capability to run up to three On/Off boilers, or a single modulating boiler with DHW requirements.

Mixing Control

As a Mixing Control, the CPU-0550 has the capability to run 2 On/Off Boilers or a single modulating boiler. Mixing types include Modulating Mixing, Floating Action Valve or Injection Pump

Differential Setpoint Control

The CPU-0550, when selected as a Setpoint Control, will allow for Dual or Differential Setpoint requirements.

Pump Sequencer

This control allows the system to sequence and cycle pumps, override pumps and turn the pump off when the outdoor temperature goes above a certain value (WWSD).

Dual Setpoint

This control is for use when one or two independent setpoints are needed.

FEATURES:

- Boiler run-time rotation
- Pump and Valve exercising (72 hours)
- DHW priority (60 minutes)
- Boiler Protection (mixing mode)
- Multiple mixing options
- Multiple pump selection control

TECHNICAL DATA & DIMENSIONS

TECHNICAL DATA

Specifications:

- 3 x Thermistor Input (10K Ohm)
- 2 x Miscellaneous Input Signal
- 3 x Relay Outputs (240VAC 5Amps) Dry Contacts
- 1 x Modulating Output / 2Amp Dry Contact (0-10VDC)
- Input: 120VAC +/- 10% 60Hz 15A Max

Weight:

0.408Kg

Dimensions:

100mm W x 168mm H x 70mm

ETL Listings:

- Meets CSA C22.2 No. 24
- Meets UL Standard 873
- ETL Control No. 3068143

Storage:

50°F to 104°F (10°C to 40°C)

RF Info:

- Contains IC: 8169A-G2M5477
- Contains FCC ID: U3O-G2M5477
- WiFi: 2.4Ghz network only

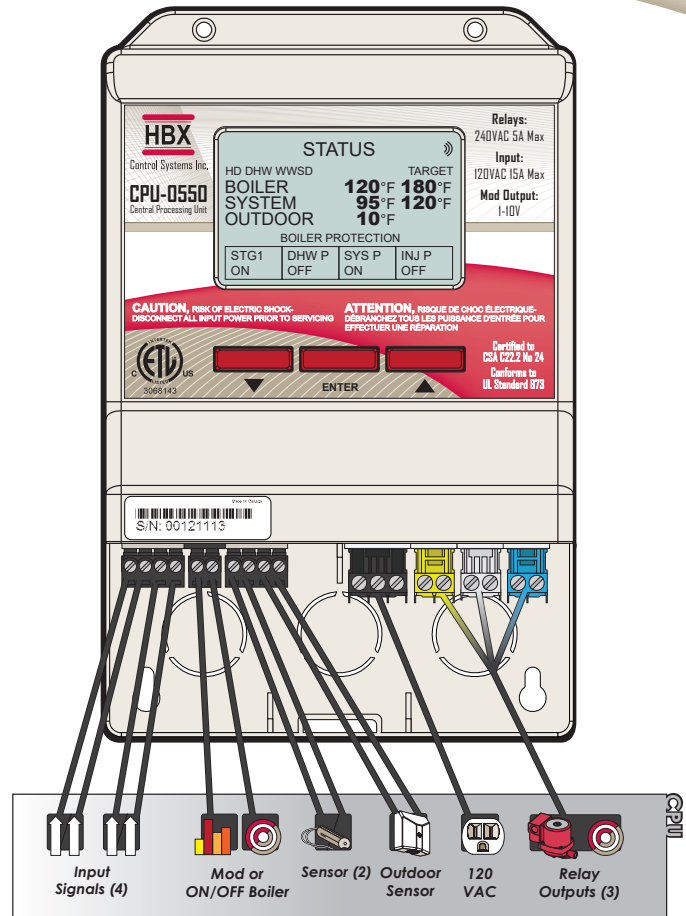

DIMENSIONS

Side View

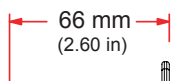

Front View

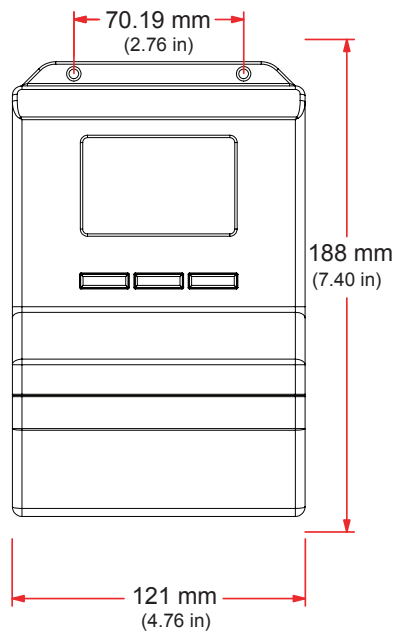

Rear View

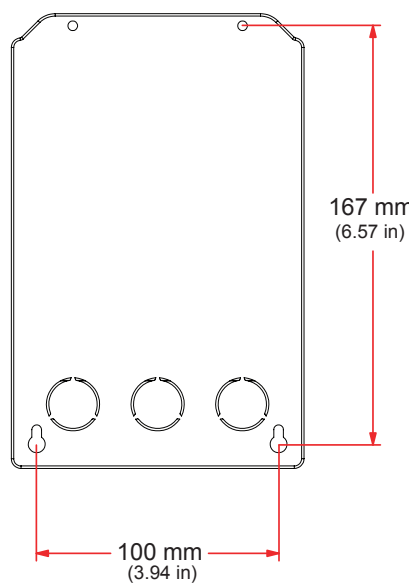

Top View

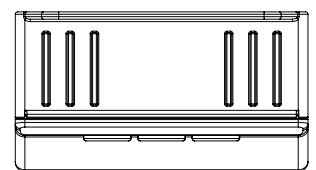

Bottom View

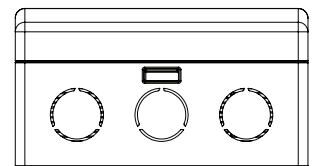

WIRING AND INSTALLATION

Wiring

All signal wiring must be with a minimum of 18AWG wire at a maximum of 500ft.

1, 2: Demand Signal 1

Apply heat demand from a dry contact, or 24VAC

3, 4: Demand Signal 2

Used for DHW or Setpoint demand.

5, 6: Modulating / Boiler Contacts

Modulating or Boiler 1 output. Also used in differential setpoint output for modulating devices.

Sensor Inputs

7, 10: Primarily used for boiler temperature but also used for setpoint 1 temperature in Setpoint controls.

8, 10: Used for DHW or setpoint on Boiler controls and low temperature system temperature on Mixing control. Also used for setpoint 2 temperature.

9, 10: Outdoor temperature. Only on Boiler and Mixing controls.

18, 19: Relay 3

Generally used as a system pump in boiler mode, injection or system pump in mixing mode or as an alarm in pump sequencer mode.

16, 17: Relay 2

Generally used as a pump contact valve or as a third stage boiler.

14, 15: Relay 1

This relay is generally a pump contact or can be used as a second stage boiler or as a third stage boiler.



(Relays 1, 2 and 3 are dry contacts and rated for a maximum of 5 Amps.)



Please ensure no power is applied to pin 5, 6 when in any modulating mode.

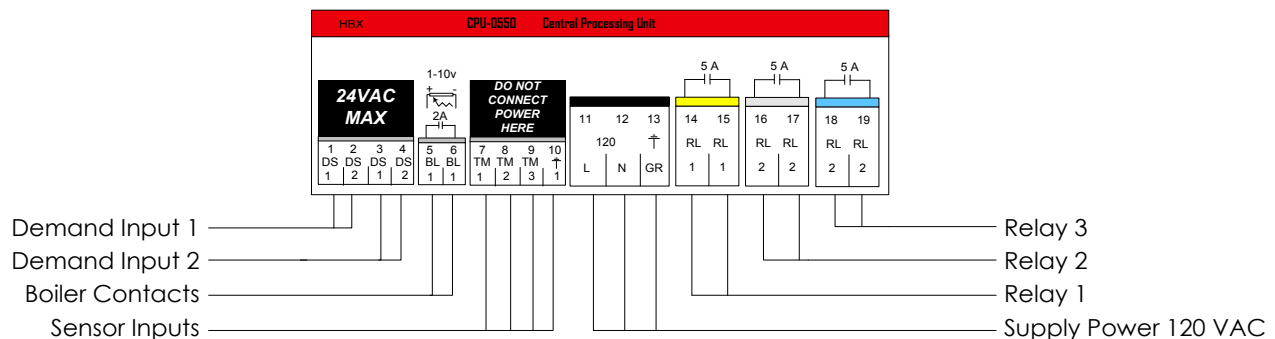

Installation

The CPU-0550 is designed to be wall mounted or installed in a separate electrical enclosure. The unit should be mounted inside and protected from falling water and high humidity conditions. With all the covers in place it is designed to protect any individual from accidental electrical shock. It is not suitable for installation in hazardous locations and should not be placed close to any electromagnetic fields.

- Identify the four mounting holes on the CPU-0550, mark on the wall the desired location of mounting.
- Pre-drill, anchor and fasten four screws for mounting.
- Hang CPU-0550 and fasten tight to desired locations
- Complete wiring connections in accordance with terminal locations.

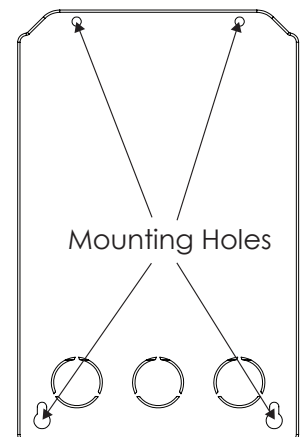

NAVIGATING THE CPU-0550

All programming steps within the CPU-0550 are achieved by using the three buttons (and combination thereof) located below the screen.

The ▼ button is used to scroll down in menu screens and decrease a value within specific options.

The ▲ button is used to scroll up in menu screens and increase a value in specific options.

The ENTER button is used to access the setpoint menu and select a setting.

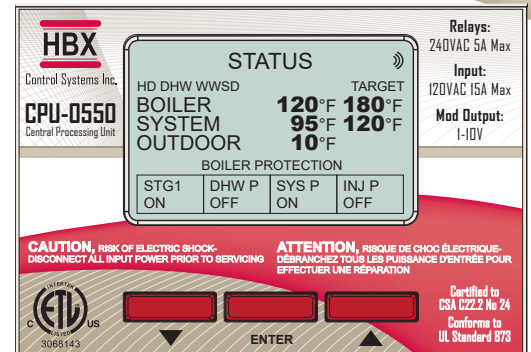

CONTROL MODE

The programming instructions for the CPU-0550 are broken down into the four control modes listed below. When the control is first plugged in you are asked to select which control mode you would like your CPU-0550 to operate in. To select your control mode simply use the ▲ or ▼ buttons to select the correct mode then wait five seconds to accept your selection.

CHOOSE CONTROL TYPE 1.04

- ▷ 1) STAGING
- 2) MIXING
- 3) DIFFERENTIAL
- 4) PUMP SEQ
- 5) DUAL SETPOINT

Boiler Mode (Default = Boiler Mode)

Programming for this mode can be found on pages 8 through 13. This mode is used when running boilers only. The boiler configurations available in this mode are single modulating, On/Off boiler, two stage On/Off boiler and three stage On/Off boiler. With single and 2 stage boiler operation the control will run the boiler pump and DHW pump.

CHOOSE CONTROL TYPE 1.04

- ▷ 1) STAGING
- ▷ 2) MIXING
- 3) DIFFERENTIAL
- 4) PUMP SEQ
- 5) DUAL SETPOINT

Mixing Mode

Programming for this mode can be found on pages 14 through 21. This mode is used when running mixing pumps or valves. Mixing configurations include PMIP, Modulating, and Floating Action Valve. In this mode the control can run up to 2 on/off boilers or a single mod boiler, depending on other options selected in the control. In modes other than Floating Valve the control will run the injection and system pump.

CHOOSE CONTROL TYPE 1.04

- 1) STAGING
- 2) MIXING
- ▷ 3) DIFFERENTIAL
- 4) PUMP SEQ
- 5) DUAL SETPOINT

Differential Setpoint Mode

Programming for this mode can be found on page 22. This mode is used when running a differential setpoint. In differential mode, the control will also send a modulating signal output based on how far the control is from the differential. This can be used to run a pump in modulating applications for constant flow.

CHOOSE CONTROL TYPE 1.04

- 1) STAGING
- 2) MIXING
- 3) DIFFERENTIAL
- ▷ 4) PUMP SEQ
- 5) DUAL SETPOINT

Pump Sequencer

Programming for this mode can be found on page 23. This mode is used to provide pump control for two pumps in a duty, standby situation. This control allows the system to sequence and cycle pumps, override pumps and turn the pumps off when the outdoor temperature goes above a certain value (WWSD)

CHOOSE CONTROL TYPE 1.04

- 1) STAGING
- 2) MIXING
- 3) DIFFERENTIAL
- 4) PUMP SEQ
- ▷ 5) DUAL SETPOINT

Dual Setpoint

Programming for this mode can be found on page 25. This mode is used when one or two independant setpoints are needed. Each setpoint is set up individually and each has its own thermistor input and relay outputs: Each setpoint has its own normally open and normally closed contacts (which can be used for heating and/or cooling).

SETUP MENU

the SETUP menu is used for entering the design values, as well as assign different control options. to access the setup menu, push the **ENTER** button on the STATUS screen. Use the ▲ or ▼ buttons to scroll through the various settings.

To select a parameter, align the cursor arrow ▶ with the desired parameter and press the **ENTER** button. the arrow will become solid ▶, which indicates that a parameter has been selected.

Adjust the setting to the desired value with the ▲ or ▼ buttons. Once the correct value is set, push the **ENTER** button. This will deselect the parameter.

To go to the previous screen, push and hold the **ENTER** button. If the SETUP menu is left for more than 90 seconds, the display will change to the STATUS screen and the control will resume operation.

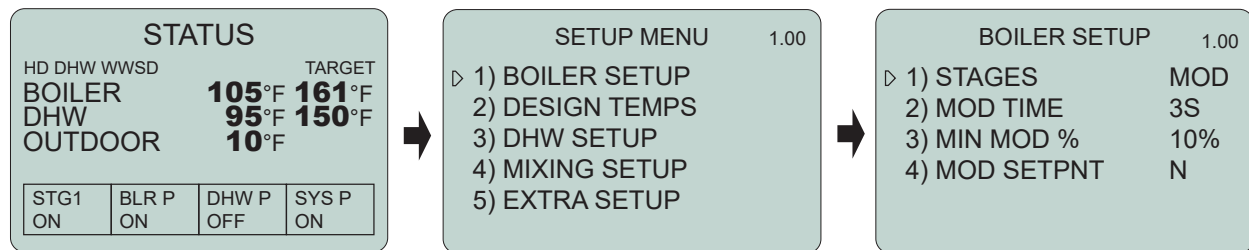

BOILER MODE

Multicolour backlit Display

The Multicolour Backlit Display is one of the key features of the HBX Controls stand-alone CPU-0550 Control. Depending on which mode of operation is selected the screen colour will change to indicate information about the status of the system.

Screen Colors

- Light Blue - No Heat Demand
- Red - Demand (DHW or Heat Demand) and Boiler running
- Yellow - Heat Demand ON, boiler running but in boiler protection
- Dark Blue - Heat Demand ON and boiler satisfied

Status Screen

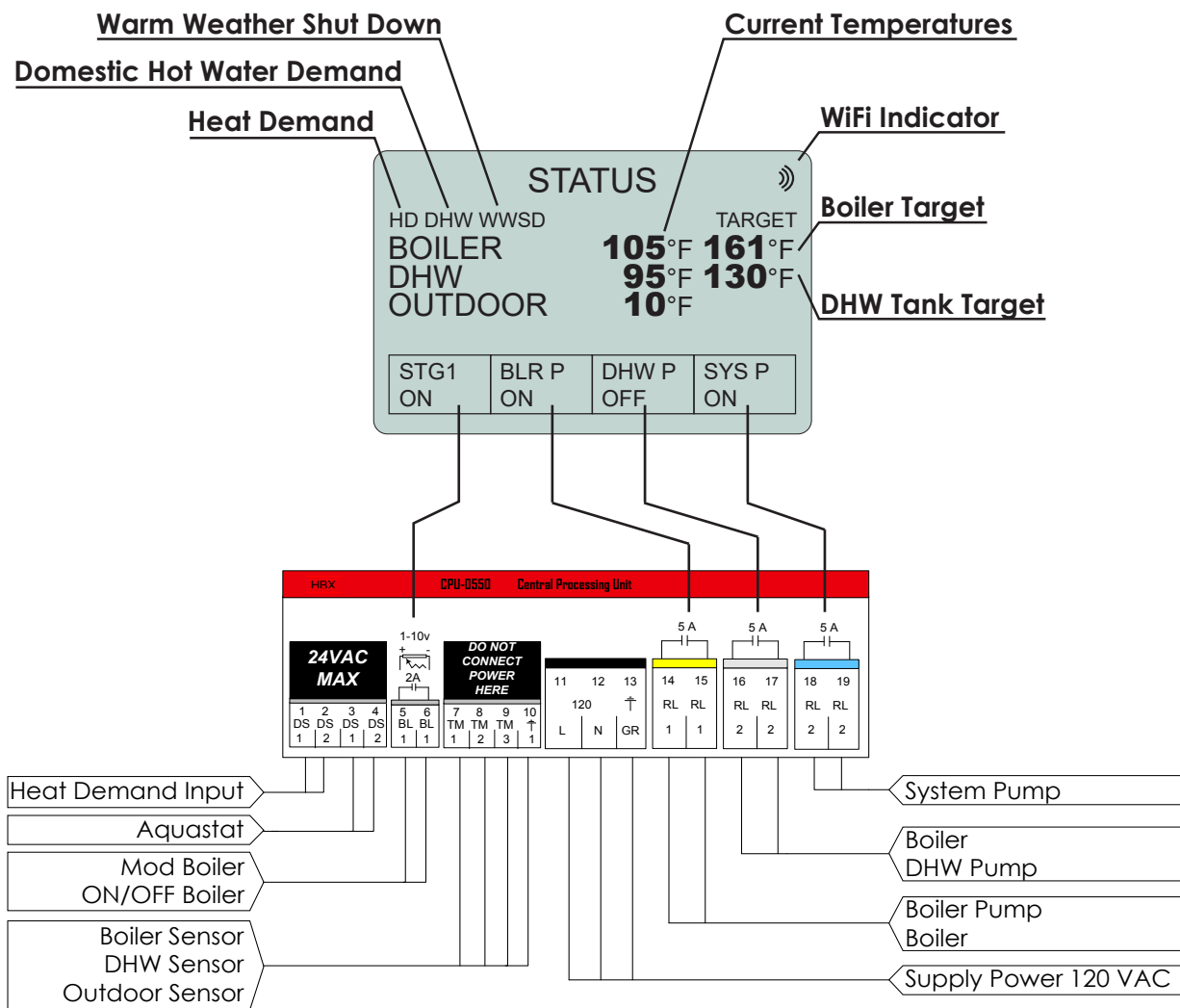

BOILER MODE PROGRAMMING GUIDE

1) BOILER SETUP

| | |
|-------------------|------|
| SETUP MENU | 1.00 |
| ▶ 1) BOILER SETUP | |
| 2) DESIGN TEMPS | |
| 3) DHW SETUP | |
| 4) HEAT DEMAND | N |
| 5) °C OR °F | °F |
| 6) WIFI | |

Boiler Setup

This setting is used to configure the boiler staging component in your system.

1 STAGE SETUP

| | |
|--------------|-------------|
| BOILER SETUP | 1.00 |
| ▶ 1) STAGES | 1 |
| 2) DIFF | 20°F |

Stages

This setting will allow you to select the boiler stage.

(1 to 3, MOD) Default: 1

| | |
|--------------|-------------|
| BOILER SETUP | 1.00 |
| 1) STAGES | 1 |
| ▶ 2) DIFF | 20°F |

Differential

Adjust this setting to the desired differential for the boiler. This will center the differential around the setpoint. (eg. 20°F would be 10°F Below and 10°F Above)

(2°F to 60°F) Default: 20°F

2/3 STAGE SETUP

| | |
|--------------|-------------|
| BOILER SETUP | 1.00 |
| ▶ 1) STAGES | 2 |
| 2) DIFF | 20°F |
| 3) ROTATE | N |
| 4) LAG TIME | 3M |

Stages

This setting will allow you to select the boiler stage.

(1 to 3, MOD) Default: 1

| | |
|--------------|-------------|
| BOILER SETUP | 1.00 |
| 1) STAGES | 2 |
| ▶ 2) DIFF | 20°F |
| 3) ROTATE | N |
| 4) LAG TIME | 3M |

Differential

Adjust this setting to the desired differential for the boiler. This will center the differential around the setpoint. (eg. 20°F would be 10°F Below and 10°F Above)

(2°F to 60°F) Default: 20°F

| | |
|--------------|-------------|
| BOILER SETUP | 1.00 |
| 1) STAGES | 2 |
| 2) DIFF | 20°F |
| ▶ 3) ROTATE | N |
| 4) LAG TIME | 3M |

Rotate

The time of rotation between boilers is 48 hours of run time. It means that the boilers are going to rotate when the first boiler exceeds the second by 48 hours and vice versa.

(Y/N) Default: N

| | |
|---------------|-------------|
| BOILER SETUP | 1.00 |
| 1) STAGES | 2 |
| 2) DIFF | 20°F |
| 3) ROTATE | N |
| ▶ 4) LAG TIME | 3M |

Lag Time

When the the boiler is set for two or more stages, this setting will be set for the minimum lag time between boiler stages. This is a time delay between stages. Even if th differential has been exceeded this time must elapse before that stage can come on.

(1M to 240M) Default: 3M

MOD BOILER SETUP

BOILER SETUP 1.00

| | |
|---------------|-----|
| ▶ 1) STAGES | MOD |
| 2) MOD TIME | 3S |
| 3) MIN MOD % | 35% |
| 4) MOD SETPNT | N |

Stages

This setting will allow you to select the boiler stage.

(1 to 3, MOD) Default: 1

BOILER SETUP 1.00

| | |
|---------------|-----|
| 1) STAGES | MOD |
| ▶ 2) MOD TIME | 3S |
| 3) MIN MOD % | 35% |
| 4) MOD SETPNT | N |

Mod Time

This setting sets the time between the steps when the boiler needs to increase or decrease the firing rate. Each step is 1% for all situations.

(1S to 240S) Default: 3S

BOILER SETUP 1.00

| | |
|----------------|-----|
| 1) STAGES | MOD |
| 2) MOD TIME | 3S |
| ▶ 3) MIN MOD % | 35% |
| 4) MOD SETPNT | N |

Minimum Mod %

This setting is used to set the lowest modulating level the boiler can go down to. This will also be the starting point whenever there is a new demand.

(10% to 95%) Default: 35%

BOILER SETUP 1.00

| | |
|-----------------|-----|
| 1) STAGES | MOD |
| 2) MOD TIME | 3S |
| 3) MIN MOD % | 35% |
| ▶ 4) MOD SETPNT | N |

Mod Setpoint

In this mode the 0-10VDC signal does not directly run the burner. The 0-10VDC signal is interpreted by the boiler as a setpoint. The boiler in this mode will modulate the burner to achieve that setpoint. ex: 4VDC is equal to 140°F

(Y/N) Default: N

2) DESIGN TEMPERATURE

| | | |
|-------------------|----|------|
| SETUP MENU | | 1.00 |
| 1) BOILER SETUP | | |
| ▶ 2) DESIGN TEMPS | | |
| 3) DHW SETUP | | |
| 4) HEAT DEMAND | N | |
| 5) °C OR °F | °F | |
| 6) WIFI | | |

Design Temperatures

Design Temperature allows you to customize each design temperature for your system

DESIGN TEMPERATURES SETUP

| | |
|--------------------------|-------|
| DESIGN TEMPERATURES 1.00 | |
| ▶ 1) OUTDOOR | 10°F |
| 2) MAX BOILER | 180°F |
| 3) MIN BOILER | 140°F |
| 4) WWSD | 70°F |

Outdoor Temperature

This is used in the outdoor reset design calculation. This option should be set to reflect your specific city or region.

(-50°F to 120°F) Default: 10°F

| | |
|--------------------------|-------|
| DESIGN TEMPERATURES 1.00 | |
| 1) OUTDOOR | 10°F |
| ▶ 2) MAX BOILER | 180°F |
| 3) MIN BOILER | 140°F |
| 4) WWSD | 70°F |

Maximum Boiler Temperature

This is used in the outdoor reset design calculation, and also serves as the maximum setting for the boiler. This is the maximum boiler temperature for the coldest day.

(140°F to 200°F) Default: 180°F

| | |
|--------------------------|-------|
| DESIGN TEMPERATURES 1.00 | |
| 1) OUTDOOR | 10°F |
| 2) MAX BOILER | 180°F |
| ▶ 3) MIN BOILER | 140°F |
| 4) WWSD | 70°F |

Minimum Boiler Temperature

This is the minimum boiler temperature. Set this to the temperature you would like the boiler to be when the outdoor temperature approaches WWSD.

(OFF/52°F to 200°F) Default: 140°F



This is the supply Boiler Temperature. Keep this in mind when selecting this feature.

| | |
|--------------------------|-------|
| DESIGN TEMPERATURES 1.00 | |
| 1) OUTDOOR | 10°F |
| 2) MAX BOILER | 180°F |
| 3) MIN BOILER | 140°F |
| ▶ 4) WWSD | 70°F |

Warm Weather Shut Down

This setting is used to set the temperature in which the CPU-0550 will go into WWSD. If the system rises above this temperature, the system will be shut off. In WWSD the boilers and all pumps will shut off.

(35°F to 120°F) Default: 70°F

3) DHW SETUP

| | |
|-----------------|------|
| SETUP MENU | 1.00 |
| 1) BOILER SETUP | |
| 2) DESIGN TEMPS | |
| ▶ 3) DHW SETUP | |
| 4) HEAT DEMAND | N |
| 5) °C OR °F | °F |
| 6) WIFI | |

Domestic Hot Water (DHW) Setup

DHW setup allows you to program domestic hot water options in your system.

DOMESTIC HOT WATER SETUP

| | |
|----------------|-------|
| DHW SETUP | 1.00 |
| ▶ 1) USE DHW | N |
| 2) PRIORITY | N |
| 3) FAST DHW | N |
| 4) BOIL SETPNT | 180°F |
| 5) SETPOINT | 130°F |
| 6) DIFF | 8°F |

Use DHW

Once this option is enabled you will be able to program the remaining options for your DHW setup.

(Y/N) Default: **N**

| | |
|----------------|-------|
| DHW SETUP | 1.00 |
| 1) USE DHW | N |
| ▶ 2) PRIORITY | N |
| 3) FAST DHW | N |
| 4) BOIL SETPNT | 180°F |
| 5) SETPOINT | 130°F |
| 6) DIFF | 8°F |

DHW Priority

This selection will allow the DHW demand to override the heating system for a max of 60 minutes in order to satisfy the DHW demand. Once 60 minutes have passed and there is still unsatisfied heat demand, the control will automatically switch back to accommodate the demand for heat.

(Y/N) Default: **N**

| | |
|----------------|-------|
| DHW SETUP | 1.00 |
| 1) USE DHW | N |
| 2) PRIORITY | N |
| ▶ 3) FAST DHW | N |
| 4) BOIL SETPNT | 180°F |
| 5) SETPOINT | 130°F |
| 6) DIFF | 8°F |

Fast DHW (Only Applies to Multiple Boiler Operation)

This option will allow all the boilers to come on immediately when there is a call for DHW. The boilers will still stage off at the normal differential. This option allows for faster DHW heating.

(Y/N) Default: **N**

| | |
|------------------|-------|
| DHW SETUP | 1.00 |
| 1) USE DHW | N |
| 2) PRIORITY | N |
| 3) FAST DHW | N |
| ▶ 4) BOIL SETPNT | 180°F |
| 5) SETPOINT | 130°F |
| 6) DIFF | 8°F |

Boiler Setpoint

This option allows you to set the maximum boiler temperature when the DHW demand is on. This will override the calculated boiler target from the designs.

(50°F to 200°F) Default: **180°F**

| | |
|----------------|-------|
| DHW SETUP | 1.00 |
| 1) USE DHW | N |
| 2) PRIORITY | N |
| 3) FAST DHW | N |
| 4) BOIL SETPNT | 180°F |
| ▶ 5) SETPOINT | 130°F |
| 6) DIFF | 8°F |

Setpoint

This option allows you to select your DHW target temperature in the tank.

(50°F to 200°F) Default: **130°F**

| | |
|----------------|-------|
| DHW SETUP | 1.00 |
| 1) USE DHW | N |
| 2) PRIORITY | N |
| 3) FAST DHW | N |
| 4) BOIL SETPNT | 180°F |
| 5) SETPOINT | 130°F |
| ▶ 6) DIFF | 8°F |

Differential

This is the differential for the DHW tank. Set this parameter to the desired differential for the DHW tank.

(2°F to 60°F) Default: **8°F**

4) HEAT DEMAND

| | |
|------------------|------|
| SETUP MENU | 1.00 |
| 1) BOILER SETUP | |
| 2) DESIGN TEMPS | |
| 3) DHW SETUP | |
| ▶ 4) HEAT DEMAND | N |
| 5) °C OR °F | °F |
| 6) WIFI | |

Heat Demand

This setting indicates that the CPU-0550 is in a permanent heat demand. This can be used instead of attaching a thermostat.

(Y/N) Default: **N**

5) CELSIUS OR FAHRENHEIT

| | |
|-----------------|------|
| SETUP MENU | 1.00 |
| 1) BOILER SETUP | |
| 2) DESIGN TEMPS | |
| 3) DHW SETUP | |
| 4) HEAT DEMAND | N |
| ▶ 5) °C OR °F | °F |
| 6) WIFI | |

Celsius or Fahrenheit

Use this setting to change the display format from Celsius (°C) to Fahrenheit (°F).

(°F/°C) Default: **°F**

6) WIFI SETUP

| | |
|-----------------|------|
| SETUP MENU | 2.00 |
| 1) HEAT PUMPS | |
| 2) TANKS | |
| 3) BACKUP | |
| 4) ENERGY CLOCK | |
| 5) PRIORITY | COLD |
| ▶ 6) WIFI | |

Wifi Setup

This setting gives the user the capability to use the CPU-0550 remotely with the HBX ThermoLinx App. This setting displays the CPU-0550 password and Sync-Code. Enter the password and Sync-Code on the HBX ThermoLinx App for remote control of the CPU-0550 on your smartphone or tablet device.

See page 28 for Wi-Fi setup information.

MIXING MODE

Multicolour backlit Display

The Multicolour Backlit Display is one of the key features of the HBX Controls stand-alone CPU-0550 Control. Depending on which mode of operation is selected the screen colour will change to indicate information about the status of the system.

Screen Colors

- Light Blue - No Heat Demand
- Red - Demand (DHW or Heat Demand) and Boiler running
- Yellow - Heat Demand ON, boiler running but in boiler protection
- Dark Blue - Heat Demand ON and boiler satisfied

Status Screen

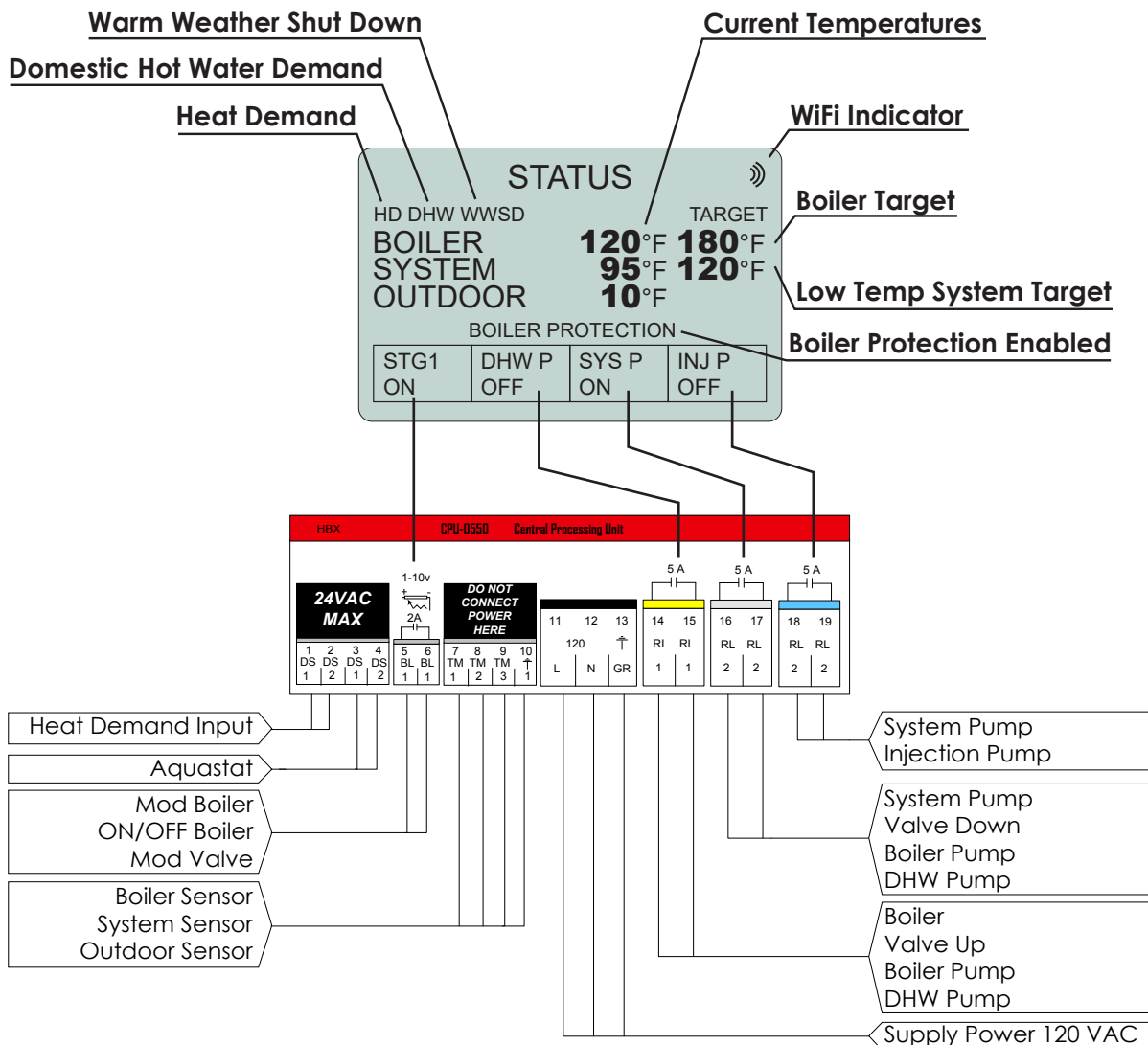

MIXING MODE PROGRAMMING GUIDE

1) BOILER SETUP

| | |
|-------------------|------|
| SETUP MENU | 1.00 |
| ▶ 1) BOILER SETUP | |
| 2) DESIGN TEMPS | |
| 3) DHW SETUP | |
| 4) MIXING SETUP | |
| 5) EXTRA SETUP | |

Boiler Setup

This setting is used to configure the boiler staging component in your system.

1 STAGE SETUP

| | |
|--------------|-------------|
| BOILER SETUP | 1.00 |
| ▶ 1) STAGES | 1 |
| 2) DIFF | 20°F |

Stages

This setting will allow you to select the boiler stage.

(1 to 3, MOD) Default: 1

| | |
|--------------|-------------|
| BOILER SETUP | 1.00 |
| 1) STAGES | 1 |
| ▶ 2) DIFF | 20°F |

Differential

Adjust this setting to the desired differential for the boiler.

(2°F to 60°F) Default: 20°F

2/3 STAGE SETUP

| | |
|--------------|-------------|
| BOILER SETUP | 1.00 |
| ▶ 1) STAGES | 2 |
| 2) DIFF | 20°F |
| 3) ROTATE | N |
| 4) LAG TIME | 3M |

Stages

This setting will allow you to select the boiler stage.

(1 to 3, MOD) Default: 1

| | |
|--------------|-------------|
| BOILER SETUP | 1.00 |
| 1) STAGES | 2 |
| ▶ 2) DIFF | 20°F |
| 3) ROTATE | N |
| 4) LAG TIME | 3M |

Differential

Adjust this setting to the desired differential for the boiler. This will center the differential around the setpoint. (eg. 10°F below/above)

(2°F to 60°F) Default: 20°F

| | |
|--------------|-------------|
| BOILER SETUP | 1.00 |
| 1) STAGES | 2 |
| 2) DIFF | 20°F |
| ▶ 3) ROTATE | N |
| 4) LAG TIME | 3M |

Rotate

The time of rotation between boilers is 48 hours of run time. It means that the boilers are going to rotate when the first boiler exceeds the second by 48 hours and vice versa.

(Y/N) Default: N

| | |
|---------------|-------------|
| BOILER SETUP | 1.00 |
| 1) STAGES | 2 |
| 2) DIFF | 20°F |
| 3) ROTATE | N |
| ▶ 4) LAG TIME | 3M |

Lag Time

When the the boiler is set for two or more stages, this setting will be set for the minimum lag time between boiler stages. This is a time delay between stages. Even if th differential has been exceeded this time must elapse before that stage can come on.

(1M to 240M) Default: 3M

MOD BOILER SETUP

BOILER SETUP 1.00

| | |
|---------------|-----|
| ▶ 1) STAGES | MOD |
| 2) MOD TIME | 3S |
| 3) MIN MOD % | 35% |
| 4) MOD SETPNT | N |

Stages

This setting will allow you to select the boiler stage.

(1 to 3, MOD) Default: 1

BOILER SETUP 1.00

| | |
|---------------|-----|
| 1) STAGES | MOD |
| ▶ 2) MOD TIME | 3S |
| 3) MIN MOD % | 35% |
| 4) MOD SETPNT | N |

Mod Time

This setting sets the time between the steps when the boiler needs to increase or decrease the firing rate. each step is 1% for all situations.

(1S to 240S) Default: 3S

BOILER SETUP 1.00

| | |
|----------------|-----|
| 1) STAGES | MOD |
| 2) MOD TIME | 3S |
| ▶ 3) MIN MOD % | 35% |
| 4) MOD SETPNT | N |

Minimum Mod %

This setting is used to set the lowest modulating level the boiler can go down to. This will also be the starting point whenever there is a new demand.

(10% to 95%) Default: 35%

BOILER SETUP 1.00

| | |
|-----------------|-----|
| 1) STAGES | MOD |
| 2) MOD TIME | 3S |
| 3) MIN MOD % | 35% |
| ▶ 4) MOD SETPNT | N |

Mod Setpoint

In this mode the 0-10VDC signal does not directly run the boiler. the 0-10VDC signal is interpreted by the boiler as a setpoint. The boiler in this mode will modulate the burner to achieve that setpoint.

(Y/N) Default: N

2) DESIGN TEMPERATURE

| | |
|-------------------|------|
| SETUP MENU | 1.00 |
| 1) BOILER SETUP | |
| ▶ 2) DESIGN TEMPS | |
| 3) DHW SETUP | |
| 4) MIXING SETUP | |
| 5) EXTRA SETUP | |

Design Temperatures

Design Temperature allows you to customize each design temperature for your system.

DESIGN TEMPERATURES SETUP

| | |
|--------------------------|-------|
| DESIGN TEMPERATURES 1.00 | |
| ▶ 1) OUTDOOR | 10°F |
| 2) MAX BOILER | 180°F |
| 3) MIN BOILER | 140°F |
| 4) SYSTEM | 120°F |
| 5) MIN SYSTEM | 70°F |
| 6) WWSD | 70°F |

Outdoor Temperature

This is used in the outdoor reset design calculation. This option should be set to reflect your specific city or region.

(-50°F to 120°F) Default: 10°F

| | |
|--------------------------|-------|
| DESIGN TEMPERATURES 1.00 | |
| 1) OUTDOOR | 10°F |
| ▶ 2) MAX BOILER | 180°F |
| 3) MIN BOILER | 140°F |
| 4) SYSTEM | 120°F |
| 5) MIN SYSTEM | 70°F |
| 6) WWSD | 70°F |

Maximum Boiler Temperature

This is used in the outdoor reset design calculation, and also serves as the maximum setting for the boiler. This is the maximum boiler temperature for the coldest day.

(140°F to 200°F) Default: 180°F

| | |
|--------------------------|-------|
| DESIGN TEMPERATURES 1.00 | |
| 1) OUTDOOR | 10°F |
| 2) MAX BOILER | 180°F |
| ▶ 3) MIN BOILER | 140°F |
| 4) SYSTEM | 120°F |
| 5) MIN SYSTEM | 70°F |
| 6) WWSD | 70°F |

Minimum Boiler Temperature

This is the minimum boiler temperature. Set this to the temperature you would like the boiler to be when the outdoor temperature approaches WWSD. **If the actual boiler temperature falls below this setting, the control will enter boiler protection mode and shut off mixing.**

(Off/52°F to 200°F) Default: 140°F



This is the supply Boiler Temperature. Keep this in mind when selecting this feature.

| | |
|--------------------------|-------|
| DESIGN TEMPERATURES 1.00 | |
| 1) OUTDOOR | 10°F |
| 2) MAX BOILER | 180°F |
| 3) MIN BOILER | 140°F |
| ▶ 4) SYSTEM | 120°F |
| 5) MIN SYSTEM | 70°F |
| 6) WWSD | 70°F |

System Temperature

This is used to setup the maximum temperature for your low temperature system on the coldest day.

(20°F to 180°F) Default: 120°F

| | |
|--------------------------|-------|
| DESIGN TEMPERATURES 1.00 | |
| 1) OUTDOOR | 10°F |
| 2) MAX BOILER | 180°F |
| 3) MIN BOILER | 140°F |
| 4) SYSTEM | 120°F |
| ▶ 5) MIN SYSTEM | 70°F |
| 6) WWSD | 70°F |

Minimum System Temperature

This is used to setup the lowest temperature you would like in the low temperature system. The setpoint will hit this when the outdoor temperature approaches WWSD.

(20°F to 180°F) Default: 120°F

| | |
|--------------------------|-------|
| DESIGN TEMPERATURES 1.00 | |
| 1) OUTDOOR | 10°F |
| 2) MAX BOILER | 180°F |
| 3) MIN BOILER | 140°F |
| 4) SYSTEM | 120°F |
| 5) MIN SYSTEM | 70°F |
| ▶ 6) WWSD | 70°F |

Warm Weather Shut Down

This setting is used to set the temperature in which the CPU-0550 will go into WWSD. If the system rises above this temperature, the system will be shut off. In WWSD the boilers and all pumps will shut off.

(35°F to 120°F) Default: 70°F

3) DHW SETUP

| | |
|-----------------|------|
| SETUP MENU | 1.00 |
| 1) BOILER SETUP | |
| 2) DESIGN TEMPS | |
| ▶ 3) DHW SETUP | |
| 4) MIXING SETUP | |
| 5) EXTRA SETUP | |

Domestic Hot Water (DHW) Setup

DHW setup allows you to program domestic hot water options in your system.

DOMESTIC HOT WATER SETUP

| | | | | | | | | | | | |
|--|-----------|------|--------------|---|-------------|---|-------------|---|----------------|-------|---|
| <table border="1" style="width: 100%; border-collapse: collapse;"> <tr> <td>DHW SETUP</td> <td>1.00</td> </tr> <tr> <td>▶ 1) USE DHW</td> <td>N</td> </tr> <tr> <td>2) PRIORITY</td> <td>N</td> </tr> <tr> <td>3) FAST DHW</td> <td>N</td> </tr> <tr> <td>4) BOIL SETPNT</td> <td>180°F</td> </tr> </table> <p style="font-size: small; margin-top: 5px;">AQUASTAT ONLY IN MIXING MODE</p> | DHW SETUP | 1.00 | ▶ 1) USE DHW | N | 2) PRIORITY | N | 3) FAST DHW | N | 4) BOIL SETPNT | 180°F | <p>Use DHW</p> <p>Once this option is enabled you will be able to program the remaining options for your DHW setup.</p> <p>(Y/N) Default: N</p> |
| DHW SETUP | 1.00 | | | | | | | | | | |
| ▶ 1) USE DHW | N | | | | | | | | | | |
| 2) PRIORITY | N | | | | | | | | | | |
| 3) FAST DHW | N | | | | | | | | | | |
| 4) BOIL SETPNT | 180°F | | | | | | | | | | |

| | | | | | | | | | | | |
|--|-----------|------|------------|---|---------------|---|-------------|---|----------------|-------|---|
| <table border="1" style="width: 100%; border-collapse: collapse;"> <tr> <td>DHW SETUP</td> <td>1.00</td> </tr> <tr> <td>1) USE DHW</td> <td>N</td> </tr> <tr> <td>▶ 2) PRIORITY</td> <td>N</td> </tr> <tr> <td>3) FAST DHW</td> <td>N</td> </tr> <tr> <td>4) BOIL SETPNT</td> <td>180°F</td> </tr> </table> <p style="font-size: small; margin-top: 5px;">AQUASTAT ONLY IN MIXING MODE</p> | DHW SETUP | 1.00 | 1) USE DHW | N | ▶ 2) PRIORITY | N | 3) FAST DHW | N | 4) BOIL SETPNT | 180°F | <p>Priority</p> <p>This selection will allow the DHW demand to override the heating system for a max of 60 minutes in order to satisfy the DHW demand. Once 60 minutes have passed and there is still unsatisfied heat demand, the control will automatically switch back to accommodate the demand for heat.</p> <p>(Y/N) Default: N</p> |
| DHW SETUP | 1.00 | | | | | | | | | | |
| 1) USE DHW | N | | | | | | | | | | |
| ▶ 2) PRIORITY | N | | | | | | | | | | |
| 3) FAST DHW | N | | | | | | | | | | |
| 4) BOIL SETPNT | 180°F | | | | | | | | | | |

| | | | | | | | | | | | |
|--|-----------|------|------------|---|-------------|---|---------------|---|----------------|-------|--|
| <table border="1" style="width: 100%; border-collapse: collapse;"> <tr> <td>DHW SETUP</td> <td>1.00</td> </tr> <tr> <td>1) USE DHW</td> <td>N</td> </tr> <tr> <td>2) PRIORITY</td> <td>N</td> </tr> <tr> <td>▶ 3) FAST DHW</td> <td>N</td> </tr> <tr> <td>4) BOIL SETPNT</td> <td>180°F</td> </tr> </table> <p style="font-size: small; margin-top: 5px;">AQUASTAT ONLY IN MIXING MODE</p> | DHW SETUP | 1.00 | 1) USE DHW | N | 2) PRIORITY | N | ▶ 3) FAST DHW | N | 4) BOIL SETPNT | 180°F | <p>Fast DHW (Only Applies to Multiple Boiler Operation)</p> <p>This option will allow all the boilers to come on immediately when there is a call for DHW. The boilers will still stage off at the normal differential. This option allows for faster DHW heating.</p> <p>(Y/N) Default: N</p> |
| DHW SETUP | 1.00 | | | | | | | | | | |
| 1) USE DHW | N | | | | | | | | | | |
| 2) PRIORITY | N | | | | | | | | | | |
| ▶ 3) FAST DHW | N | | | | | | | | | | |
| 4) BOIL SETPNT | 180°F | | | | | | | | | | |

| | | | | | | | | | | | |
|--|-----------|------|------------|---|-------------|---|-------------|---|------------------|-------|---|
| <table border="1" style="width: 100%; border-collapse: collapse;"> <tr> <td>DHW SETUP</td> <td>1.00</td> </tr> <tr> <td>1) USE DHW</td> <td>N</td> </tr> <tr> <td>2) PRIORITY</td> <td>N</td> </tr> <tr> <td>3) FAST DHW</td> <td>N</td> </tr> <tr> <td>▶ 4) BOIL SETPNT</td> <td>180°F</td> </tr> </table> <p style="font-size: small; margin-top: 5px;">AQUASTAT ONLY IN MIXING MODE</p> | DHW SETUP | 1.00 | 1) USE DHW | N | 2) PRIORITY | N | 3) FAST DHW | N | ▶ 4) BOIL SETPNT | 180°F | <p>Boiler Setpoint</p> <p>This option allows you to set the maximum boiler temperature when the DHW demand is on. This will override the calculated boiler target from the designs.</p> <p>(50°F to 200°F) Default: 180°F</p> |
| DHW SETUP | 1.00 | | | | | | | | | | |
| 1) USE DHW | N | | | | | | | | | | |
| 2) PRIORITY | N | | | | | | | | | | |
| 3) FAST DHW | N | | | | | | | | | | |
| ▶ 4) BOIL SETPNT | 180°F | | | | | | | | | | |

4) MIXING SETUP

| | |
|-------------------|------|
| SETUP MENU | 1.00 |
| 1) BOILER SETUP | |
| 2) DESIGN TEMPS | |
| 3) DHW SETUP | |
| ▶ 4) MIXING SETUP | |
| 5) EXTRA SETUP | |

Mixing Setup

Mixing Setup is used to select your mixing device.

INJECTION PUMP MIXING SETUP

| | |
|------------------|------|
| MIXING MENU | 1.00 |
| ▶ 1) MIXING TYPE | INJ |

Mixing Type

Use this option when using a primary/secondary injection style piping. This selection will take hot water from the primary loop and inject it into the secondary loop, ensuring proper temperature control in the low temperature system.

(INJ/FLO/MOD) Default: **INJ**

FLOATING ACTION VALVE SETUP

| | |
|------------------|------|
| MIXING MENU | 1.00 |
| ▶ 1) MIXING TYPE | FLO |

Mixing Type

Use this option when you are using a 3 or 4 way mixing valve. This will run your floating (power open/power close valve) and mix the temperature down in your low temperature system.

(INJ/FLO/MOD) Default: **INJ**

MODULATING OUTPUT SETUP

| | |
|------------------|------|
| MIXING MENU | 1.00 |
| ▶ 1) MIXING TYPE | MOD |
| 2) MOD TIME | 3S |
| 3) MIN MOD% | 10% |

Mixing Type

Use this option when you need to have a 1-10VDC signal to run your mixing device. This could be used for a modulating valve or to a VFD, to ensure the proper temperature in the low temperature system.

(INJ/FLO/MOD) Default: **INJ**

| | |
|----------------|------|
| MIXING MENU | 1.00 |
| 1) MIXING TYPE | MOD |
| ▶ 2) MOD TIME | 3S |
| 3) MIN MOD% | 10% |

Mod Time

This setting sets the time between the steps when the valve needs to increase or decrease the firing rate. Each step is 1% for all situations.

(1S to 240S) Default: **3S**

| | |
|----------------|------|
| MIXING MENU | 1.00 |
| 1) MIXING TYPE | MOD |
| 2) MOD TIME | 3S |
| ▶ 3) MIN MOD% | 10% |

Minimum Mod %

This setting is used to set the lowest modulating level the valve can go down to. This will also be the starting point whenever there is a new demand.

(10% to 95%) Default: **10%**

5) EXTRA SETUP

| | |
|------------------|------|
| SETUP MENU | 1.00 |
| 1) BOILER SETUP | |
| 2) DESIGN TEMPS | |
| 3) DHW SETUP | |
| 4) MIXING SETUP | |
| ▶ 5) EXTRA SETUP | |

Extra Setup

This option allows access to Heat Demand, Celsius or Fahrenheit and WiFi setup.

EXTRA SETUP

| | |
|------------------|------|
| EXTRA SETUP | 1.00 |
| ▶ 1) HEAT DEMAND | N |
| 2) °C OR °F | °F |
| 3) WIFI | |

1) Heat Demand

This setting indicates that the CPU-0550 is in a permanent heat demand. This can be used instead of attaching a thermostat.

(Y/N) Default: **N**

| | |
|----------------|------|
| EXTRA SETUP | 1.00 |
| 1) HEAT DEMAND | N |
| ▶ 2) °C OR °F | °F |
| 3) WIFI | |

2) Celsius or Fahrenheit

Use this setting to change the display format from Celsius (°C) to Fahrenheit (°F).

(°F/°C) Default: **°F**

| | |
|----------------|------|
| EXTRA SETUP | 1.00 |
| 1) HEAT DEMAND | N |
| 2) °C OR °F | °F |
| ▶ 3) WIFI | |

3) Wifi Setup

This setting gives the user the capability to use the CPU-0550 remotely with the HBX ThermoLinx App. This setting displays the CPU-0550 password and Sync-Code. Enter the password and Sync-Code on the HBX ThermoLinx App for remote control of the CPU-0550 on your smartphone or tablet device.

5) EXTRA SETUP: WIFI SETUP

| | |
|----------------|------|
| EXTRA SETUP | 1.00 |
| 1) HEAT DEMAND | N |
| 2) °C OR °F | °F |
| ▶ 3) WIFI | |

Wifi Setup

This setting gives the user the capability to use the CPU-0550 remotely with the HBX ThermoLinx App. This setting displays the CPU-0550 password and Sync-Code. Enter the password and Sync-Code on the HBX ThermoLinx App for remote control of the CPU-0550 on your smartphone or tablet device.

See page 28 for Wi-Fi setup information.

DIFFERENTIAL SETPOINT MODE

Multicolour backlit Display

The Multicolour Backlit Display is one of the key features of the HBX Controls stand-alone CPU-0550 Control. Depending on which mode of operation is selected the screen colour will change to indicate information about the status of the system.

Screen Colors

Light Blue - No Heat Demand
Red - Heat Demand

Status Screen

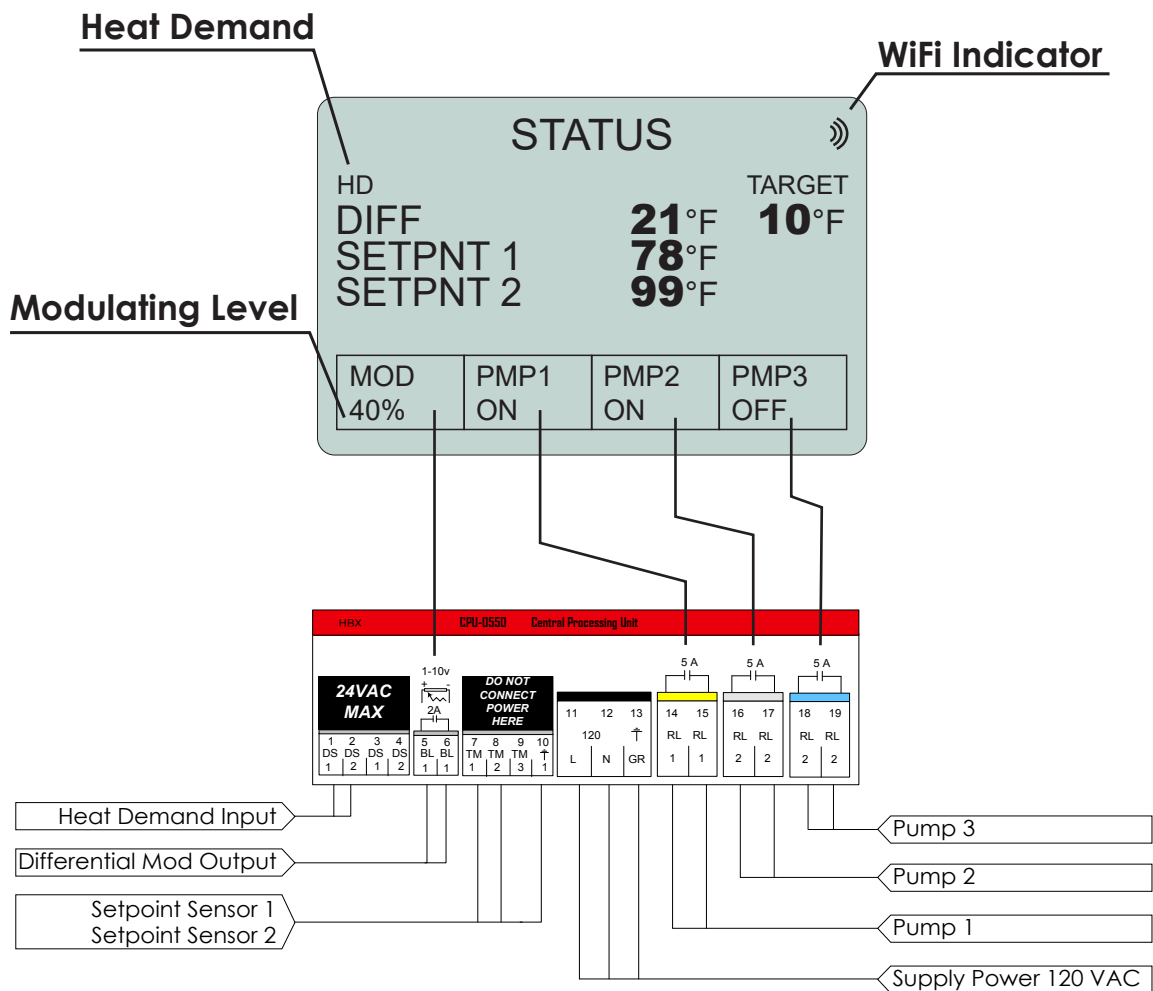

DIFFERENTIAL SETPOINT MODE PROGRAMMING GUIDE

DIFFERENTIAL SETPOINT SETUP

| | |
|-------------|------|
| SETUP MENU | 1.00 |
| ▶ 1) DIFF | 6°F |
| 2) MOD TIME | 3S |
| 3) MIN MOD | 30% |
| 4) °C OR °F | °F |
| 5) WIFI | |

1) Differential

Use this setting to set the differential between setpoint 1's temperature and setpoint 2's temperature.

(1°F to 100°F) Default: 6°F

| | |
|---------------|------|
| SETUP MENU | 1.00 |
| 1) DIFF | 6°F |
| ▶ 2) MOD TIME | 3S |
| 3) MIN MOD | 30% |
| 4) °C OR °F | °F |
| 5) WIFI | |

2) Mod Time

This setting sets the time between each step of the 0-10VDC output when the modulating output needs to increase or decrease.

(1S to 240S) Default: 3S

| | |
|--------------|------|
| SETUP MENU | 1.00 |
| 1) DIFF | 6°F |
| 2) MOD TIME | 3S |
| ▶ 3) MIN MOD | 30% |
| 4) °C OR °F | °F |
| 5) WIFI | |

3) Minimum Mod %

This setting is used to set the lowest modulation level the modulating output can go down to. It can also be used to set the minimum position on valves.

(10% to 95%) Default: 30%

| | |
|---------------|------|
| SETUP MENU | 1.00 |
| 1) DIFF | 6°F |
| 2) MOD TIME | 3S |
| 3) MIN MOD | 30% |
| ▶ 4) °C OR °F | °F |
| 5) WIFI | |

4) Celsius or Fahrenheit

Use this setting to change the display format from Celsius (°C) to Fahrenheit (°F).

(°F/°C) Default: °F

| | |
|-------------|------|
| SETUP MENU | 1.00 |
| 1) DIFF | 6°F |
| 2) MOD TIME | 3S |
| 3) MIN MOD | 30% |
| 4) °C OR °F | °F |
| ▶ 5) WIFI | |

5) Wifi Setup

This setting gives the user the capability to use the CPU-0550 remotely with the HBX ThermoLinX App. This setting displays the CPU-0550 password and Sync-Code. Enter the password and Sync-Code on the HBX ThermoLinX App for remote control of the CPU-0550 on your smartphone or tablet device.

DIFFERENTIAL SETPOINT: WIFI SETUP

| | |
|-------------|------|
| SETUP MENU | 1.00 |
| 1) DIFF | 6°F |
| 2) MOD TIME | 3S |
| 3) MIN MOD | 30% |
| 4) °C OR °F | °F |
| ▶ 5) WIFI | |

Wifi Setup

This setting gives the user the capability to use the CPU-0550 remotely with the HBX ThermoLinX App. This setting displays the CPU-0550 password and Sync-Code. Enter the password and Sync-Code on the HBX ThermoLinX App for remote control of the CPU-0550 on your smartphone or tablet device.

See page 28 for Wi-Fi setup information.

PUMP SEQUENCER MODE

STATUS SCREEN

Multicolour backlit Display

The Multicolour Backlit Display is one of the key features of the HBX Controls stand-alone CPU-0550 Control. Depending on which mode of operation is selected the screen colour will change to indicate information about the status of the system.

Screen Colours

Light Blue - No Demand

Dark Blue - Pump Running

Flashing Red/Blue - No flow. This happens after 10 no flow attempts on each pump

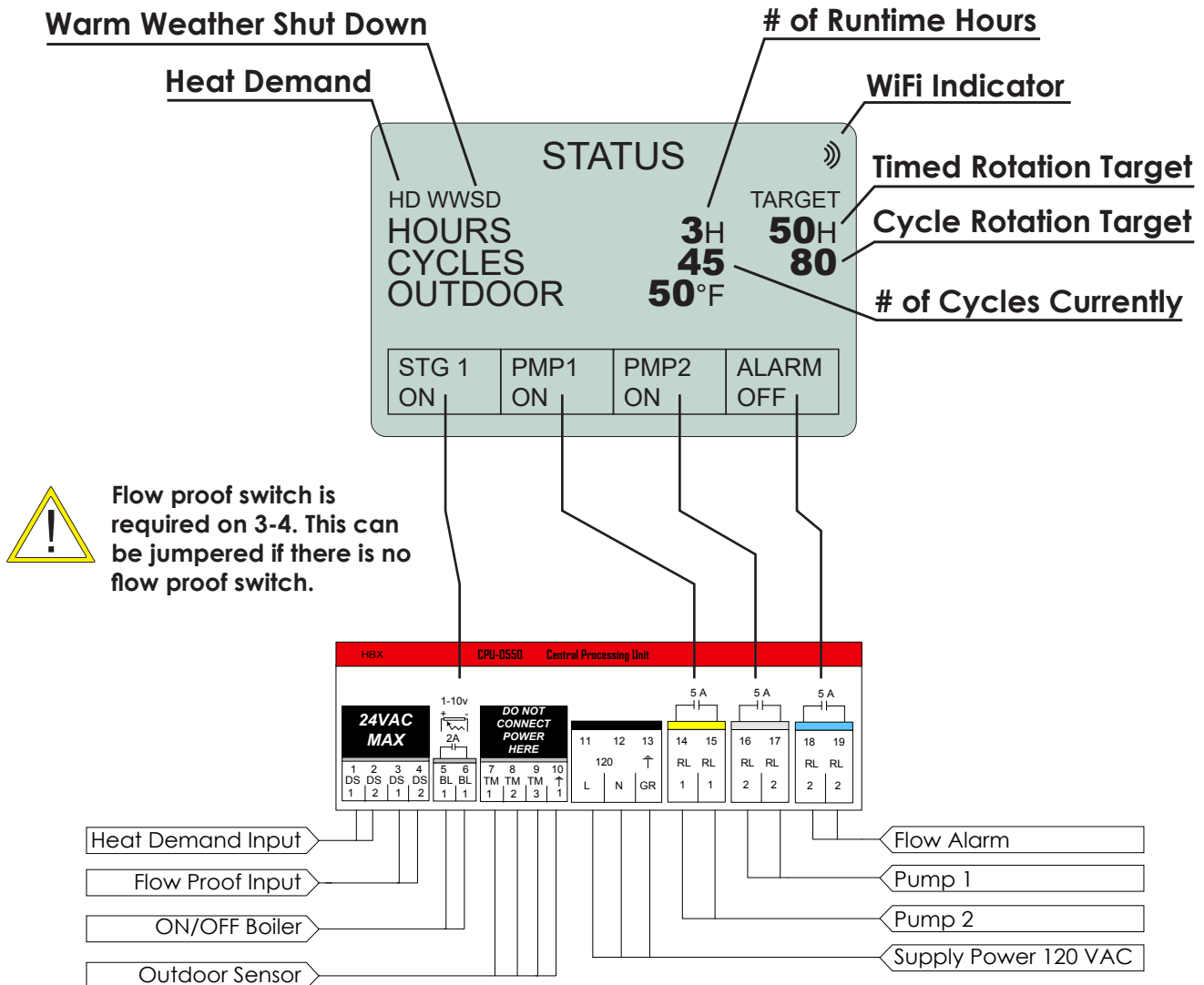

PUMP SEQUENCER MODE PROGRAMMING GUIDE

PUMP SEQUENCER SETUP

| | |
|-----------------|------|
| SETUP MENU | 1.00 |
| ▶ 1) OVERRIDE 1 | N |
| 2) OVERRIDE2 | N |
| 3) SEQ TIME | OFF |
| 4) SEQ CYCLES | OFF |
| 5) EXTRA SETUP | |

1) Manual Override 1

This setting is used to put Pump 1 in manual override. When set to yes, the pump relay is permanently on.

(Y/N) Default: **N**

| | |
|----------------|------|
| SETUP MENU | 1.00 |
| 1) OVERRIDE 1 | N |
| ▶ 2) OVERRIDE2 | N |
| 3) SEQ TIME | OFF |
| 4) SEQ CYCLES | OFF |
| 5) EXTRA SETUP | |

2) Manual Override 2

This setting is used to put Pump 2 in manual override. When set to yes, the pump relay is permanently on.

(Y/N) Default: **N**

| | |
|----------------|------|
| SETUP MENU | 1.00 |
| 1) OVERRIDE 1 | N |
| 2) OVERRIDE2 | N |
| ▶ 3) SEQ TIME | OFF |
| 4) SEQ CYCLES | OFF |
| 5) EXTRA SETUP | |

3) Sequential Time

This setting is used to set the rotation time for the pumps.

(OFF/1 to 240H) Default: **72H**

| | |
|-----------------|------|
| SETUP MENU | 1.00 |
| 1) OVERRIDE 1 | N |
| 2) OVERRIDE2 | N |
| 3) SEQ TIME | OFF |
| ▶ 4) SEQ CYCLES | OFF |
| 5) EXTRA SETUP | |

4) Sequential Cycles

This setting is used to set the number of demands that are given before the pumps will rotate.

(OFF/1 to 240 Cycles) Default: **OFF**



Use caution. Sequential Time and Sequential Cycles will override each other. Use only one or the other.

| | |
|------------------|------|
| SETUP MENU | 1.00 |
| 1) OVERRIDE 1 | N |
| 2) OVERRIDE2 | N |
| 3) SEQ TIME | OFF |
| 4) SEQ CYCLES | OFF |
| ▶ 5) EXTRA SETUP | |

5) Extra Setup

This option allows access to Heat Demand, Celcius or Farenheit and WiFi setup.

PUMP SEQUENCER: EXTRA SETUP

| SETUP MENU | | 1.00 |
|------------------|-----|------|
| 1) OVERRIDE 1 | N | |
| 2) OVERRIDE2 | N | |
| 3) SEQ TIME | OFF | |
| 4) SEQ CYCLES | OFF | |
| ▶ 5) EXTRA SETUP | | |

Extra Setup

This option allows access to Heat Demand, Celcius or Farenheit and WiFi setup.

EXTRA SETUP

| EXTRA SETUP | | 1.00 |
|-------------|------|------|
| ▶ 1) WWSD | 60°F | |
| 2) °C OR °F | °F | |
| 3) WIFI | | |

1) Warm Weather Shut Down

This setting is used to set the temperature in which the CPU-0550 will go into WWSD. If the system rises above this temperature, the system will be shut off. In WWSD the boilers and all pumps will shut off.

(35°F to 120°F) Default: 120°F

| EXTRA SETUP | | 1.00 |
|---------------|------|------|
| 1) WWSD | 60°F | |
| ▶ 2) °C OR °F | °F | |
| 3) WIFI | | |

2) Celsius or Fahrenheit

Use this setting to change the display format from Celsius (°C) to Fahrenheit (°F).

(°F/°C) Default: °F

| EXTRA SETUP | | 1.00 |
|-------------|------|------|
| 1) WWSD | 60°F | |
| 2) °C OR °F | °F | |
| ▶ 3) WIFI | | |

3) Wifi Setup

This setting gives the user the capability to use the CPU-0550 remotely with the HBX ThermoLinX App. This setting displays the CPU-0550 password and Sync-Code. Enter the password and Sync-Code on the HBX ThermoLinX App for remote control of the CPU-0550 on your smartphone or tablet device.

PUMP SEQUENCER: WIFI SETUP

| EXTRA SETUP | | 1.00 |
|-------------|------|------|
| 1) WWSD | 60°F | |
| 2) °C OR °F | °F | |
| ▶ 3) WIFI | | |

Wifi Setup

This setting gives the user the capability to use the CPU-0550 remotely with the HBX ThermoLinX App. This setting displays the CPU-0550 password and Sync-Code. Enter the password and Sync-Code on the HBX ThermoLinX App for remote control of the CPU-0550 on your smartphone or tablet device.

See page 28 for Wi-Fi setup information.

DUAL SETPOINT MODE

STATUS SCREEN

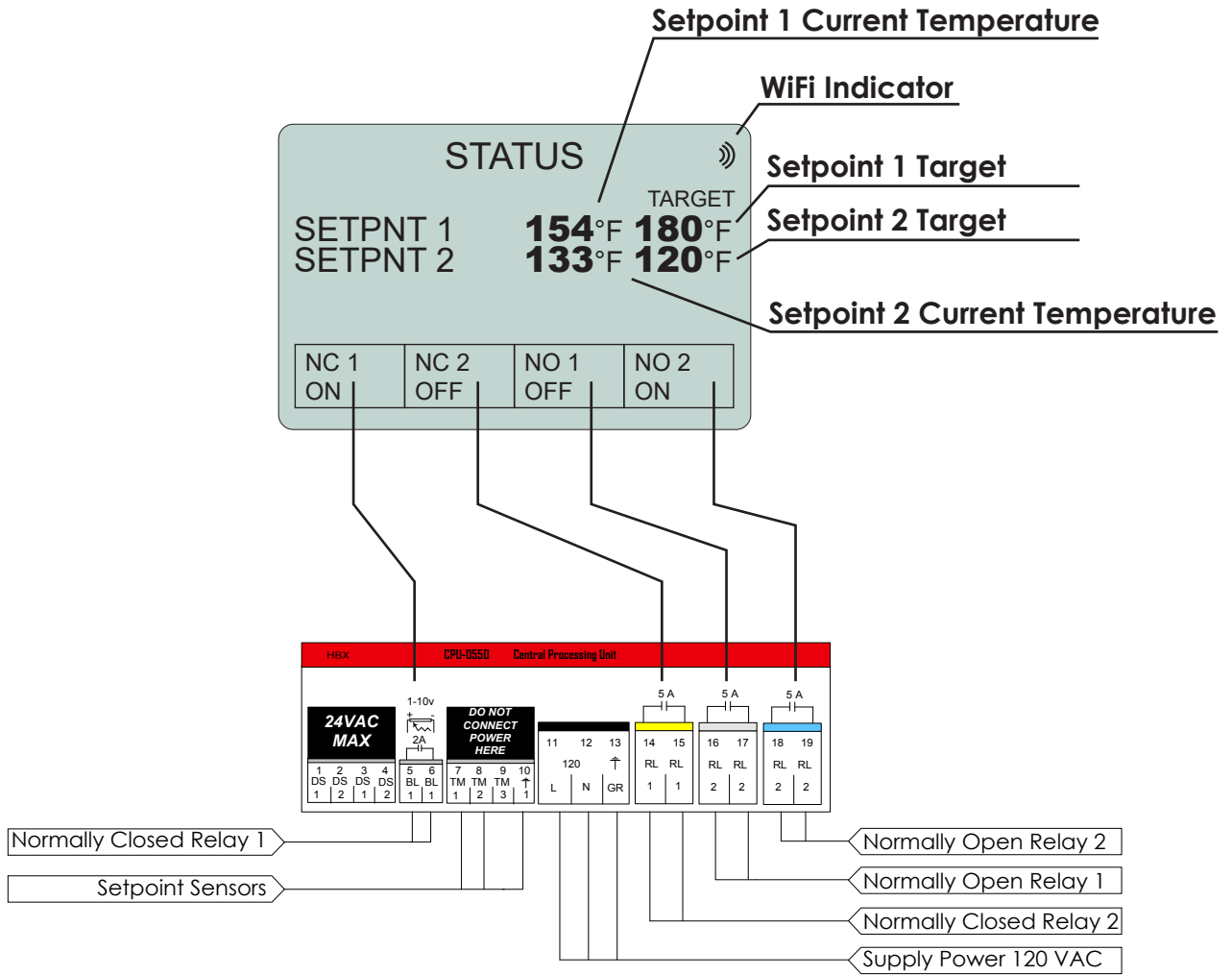

Normally Closed is typically used in a heating logic application. Normally Open is typically used in a cooling logic application.

DUAL SETPOINT MODE PROGRAMMING GUIDE

DUAL SETPOINT SETUP

| SETUP MENU | | 1.04 |
|----------------|--------------|------|
| ▶ 1) SP 1 TEMP | 180°F | |
| 2) SP 1 DIFF | 6°F | |
| 3) SP 2 TEMP | 120°F | |
| 4) SP 2 DIFF | 8°F | |
| 5) EXTRA SETUP | | |

1) Setpoint 1 Temperature

This setting is used to set the desired temperature for setpoint 1.

(1°F to 200°F) Default: **180°F**

| SETUP MENU | | 1.04 |
|----------------|--------------|------|
| 1) SP 1 TEMP | 180°F | |
| ▶ 2) SP 1 DIFF | 6°F | |
| 3) SP 2 TEMP | 120°F | |
| 4) SP 2 DIFF | 8°F | |
| 5) EXTRA SETUP | | |

2) Setpoint 1 Differential

This setting is used to set the differential for setpoint 1.

(2°F to 100°F) Default: **6°F**



6°F differential would be 6°F above and 6°F below the target

| SETUP MENU | | 1.04 |
|----------------|--------------|------|
| 1) SP 1 TEMP | 180°F | |
| 2) SP 1 DIFF | 6°F | |
| ▶ 3) SP 2 TEMP | 120°F | |
| 4) SP 2 DIFF | 8°F | |
| 5) EXTRA SETUP | | |

3) Setpoint 2 Temperature

This setting is used to set the desired temperature for setpoint 2.

(1°F to 200°F) Default: **120°F**

| SETUP MENU | | 1.04 |
|----------------|--------------|------|
| 1) SP 1 TEMP | 180°F | |
| 2) SP 1 DIFF | 6°F | |
| 3) SP 2 TEMP | 120°F | |
| ▶ 4) SP 2 DIFF | 8°F | |
| 5) EXTRA SETUP | | |

4) Setpoint 2 Differential

This setting is used to set the differential for setpoint 2.

(2°F to 100°F) Default: **6°F**



8°F differential would be 8°F above and 8°F below the target

| SETUP MENU | | 1.04 |
|------------------|--------------|------|
| 1) SP 1 TEMP | 180°F | |
| 2) SP 1 DIFF | 6°F | |
| 3) SP 2 TEMP | 120°F | |
| 4) SP 2 DIFF | 8°F | |
| ▶ 5) EXTRA SETUP | | |

5) Extra Setup

This option allows access to Heat Demand, Celcius or Farenheit and WiFi setup.

DUAL SETPOINT: EXTRA SETUP

| SETUP MENU | | 1.04 |
|------------------|--------------|------|
| 1) SP 1 TEMP | 180°F | |
| 2) SP 1 DIFF | 6°F | |
| 3) SP 2 TEMP | 120°F | |
| 4) SP 2 DIFF | 8°F | |
| ▶ 5) EXTRA SETUP | | |

Extra Setup

This option allows access to Heat Demand, Celcius or Farenheit and WiFi setup.

EXTRA SETUP

| EXTRA SETUP | | 1.00 |
|--------------|-----------|------|
| ▶ 1) LAGTIME | 3M | |
| 2) °C OR °F | °F | |
| 3) WIFI | | |

1) Lagtime

This setting is used to set lagtime. When this is set above zero, the control will wait the specified amount of time in minutes before turning the relays on.

(0M to 240M) Default: **3M**

| EXTRA SETUP | | 1.00 |
|---------------|-----------|------|
| 1) LAGTIME | 3M | |
| ▶ 2) °C OR °F | °F | |
| 3) WIFI | | |

2) Celsius or Fahrenheit

Use this setting to change the display format from Celsius (°C) to Fahrenheit (°F).

(°F/°C) Default: °F

| EXTRA SETUP | | 1.00 |
|-------------|-----------|------|
| 1) LAGTIME | 3M | |
| 2) °C OR °F | °F | |
| ▶ 3) WIFI | | |

3) Wifi Setup

This setting gives the user the capability to use the CPU-0550 remotely with the HBX ThermoLinx App. This setting displays the CPU-0550 password and Sync-Code. Enter the password and Sync-Code on the HBX ThermoLinx App for remote control of the CPU-0550 on your smartphone or tablet device.

DUAL SETPOINT: WIFI SETUP

| EXTRA SETUP | | 1.00 |
|-------------|-----------|------|
| 1) LAGTIME | 3M | |
| 2) °C OR °F | °F | |
| ▶ 3) WIFI | | |

Wifi Setup

This setting gives the user the capability to use the CPU-0550 remotely with the HBX ThermoLinx App. This setting displays the CPU-0550 password and Sync-Code. Enter the password and Sync-Code on the HBX ThermoLinx App for remote control of the CPU-0550 on your smartphone or tablet device.

See page 28 for Wi-Fi setup information.

WIFI SETUP

| SETUP WIFI | |
|---------------------|-------|
| ▶ 1) PASSWORD | AB12 |
| 2) SETUP WIFI | |
| 3) CONNECTION | READY |
| SYNC-CODE ACPU-1234 | |

Password

This is the password for the device, selecting this option allows you to change the device's password to secure the privacy of this device when needed.

No: Password will remain the same.

Yes: The control will randomly generate a new password.

| CHANGE PASSWORD | |
|-----------------|--|
| ▶ 1) NO | |
| 2) YES | |

| SETUP WIFI | |
|---------------------|-------|
| 1) PASSWORD | AB12 |
| ▶ 2) SETUP WIFI | |
| 3) CONNECTION | READY |
| SYNC-CODE ACPU-1234 | |

Setup WIFI

SSID: This will display the connected network or can also be selected to manually enter a network

1) Network name location

2) NEXT: When inputing the password select this to input the next letter or number in the sequence of the password

3) DELETE: When inputing the password use this to delete the letter or number, this will return you to the previous sequence

4) DONE: When you have correctly inputed the password select done to return to the previous screen

| SETUP WIFI | |
|----------------------|--|
| ▶ 1) SSID | |
| 2) PASSWORD | |
| 3) SCAN FOR NETWORKS | |
| 4) SEND TO WIFI | |
| SYNC-CODE ACPU-1234 | |

Password: This will display the password for the network, select this to manually enter the password

1) Password location

2) NEXT: When inputing the password select this to input the next letter or number in the sequence of the password

3) DELETE: When inputing the password use this to delete the letter or number, this will return you to the previous sequence

4) DONE: When you have correctly inputed the password select done to return to the previous screen

| SETUP WIFI | |
|----------------------|--|
| 1) SSID | |
| ▶ 2) PASSWORD | |
| 3) SCAN FOR NETWORKS | |
| 4) SEND TO WIFI | |
| SYNC-CODE ACPU-1234 | |

| SETUP WIFI | |
|------------------------|--|
| 1) SSID | |
| 2) PASSWORD | |
| ▶ 3) SCAN FOR NETWORKS | |
| 4) SEND TO WIFI | |
| SYNC-CODE ACPU-1234 | |

Scan for Networks: Selecting this will automatically scan for all available networks

SSID: press the enter button then using the up and down keys select your network, once it is selected hold the middle key for 2 seconds to return to the previous screen.

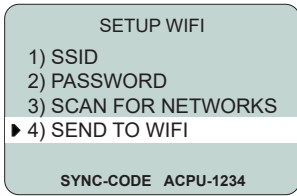

Send to WIFI: Select this once you have correctly entered the password to the selected Network. The control will send the SSID and password upon which it will automatically connect. Press and hold the enter button for 2 seconds to return to the WIFI SETTINGS screen. CONNECTION should change from WIFI to SERVER. Once this happens the CPU-0550 is now connected to the network.

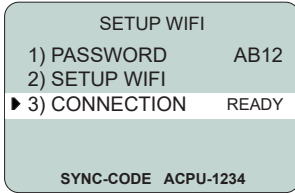

Connection

This option displays the current Wi-Fi connection status.

Ready: Awaiting for Wi-Fi setup. Control is not connected to a Wi-Fi internet network.

Wi-Fi: The control is connected to a Wi-Fi network, but unable to communicate with our server, ensure that PORT 1314 is open

Server: The control is connected to a Wi-Fi network and is communicating with the ThermoLinX server. You can now add the device to the ThermoLinX App.

1. Once connected, the CPU-0550 control will display a constant Wi-Fi Symbol on the top right corner of the main status screen, and in the Wi-Fi menu Connection will say SERVER.

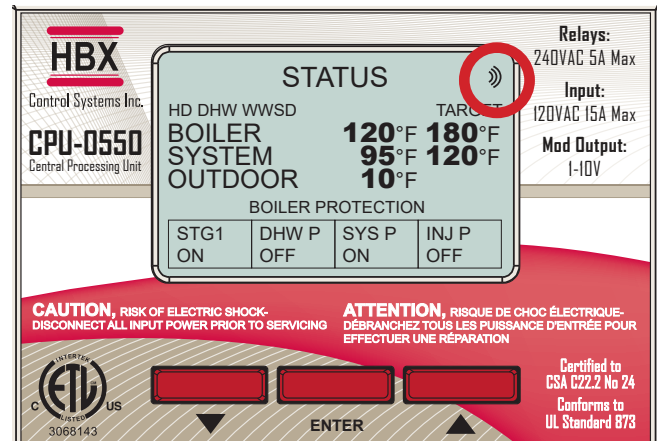

STAGING MODE WIRING DIAGRAMS

1) Single On/Off boiler with DHW pump

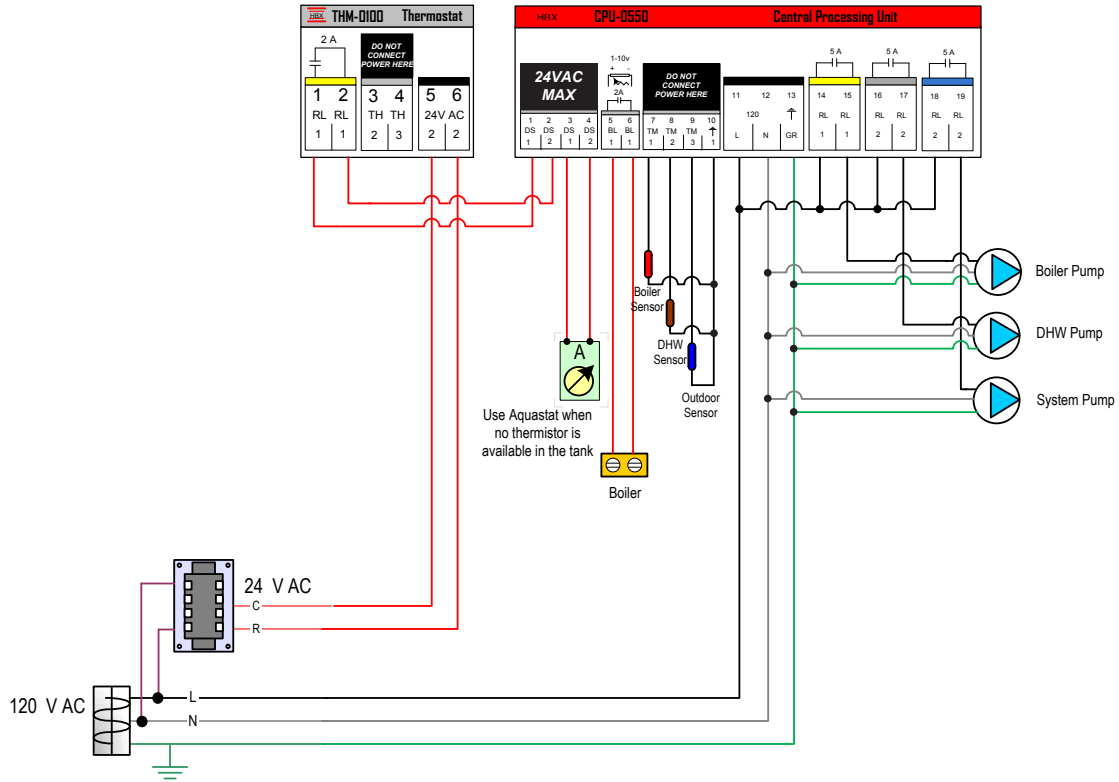

2) Two On/Off boilers with DHW pump

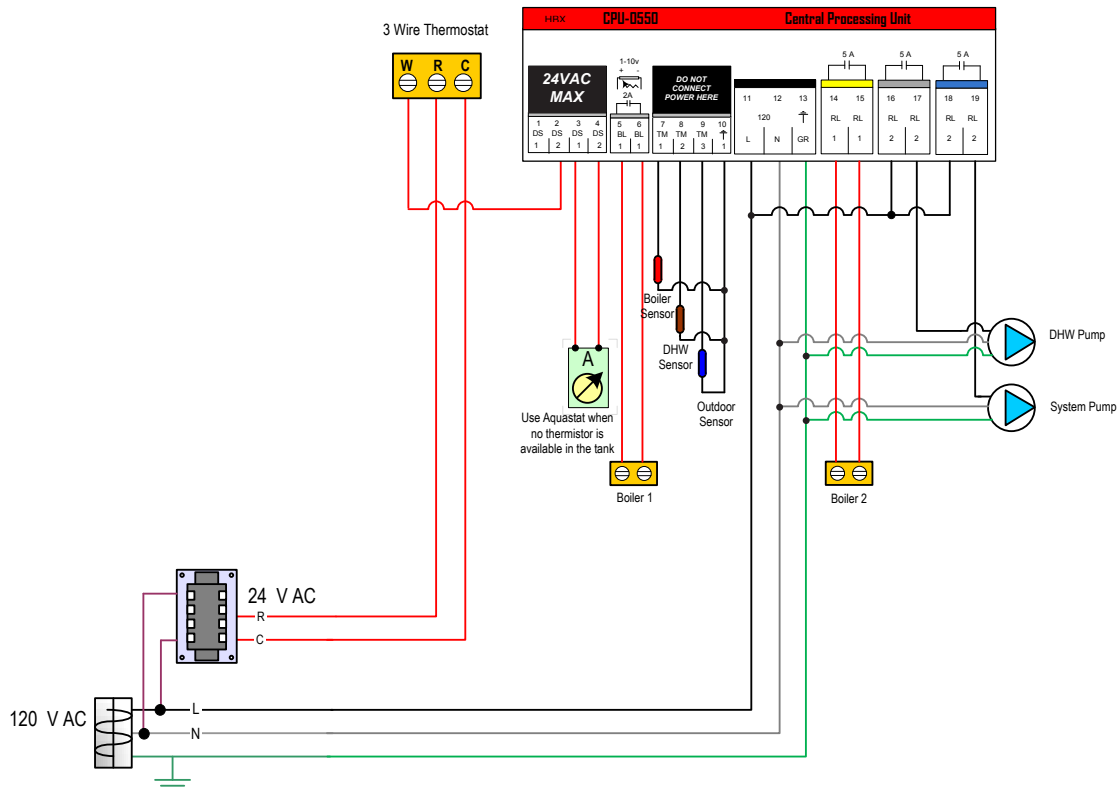

3) Three On/Off boilers

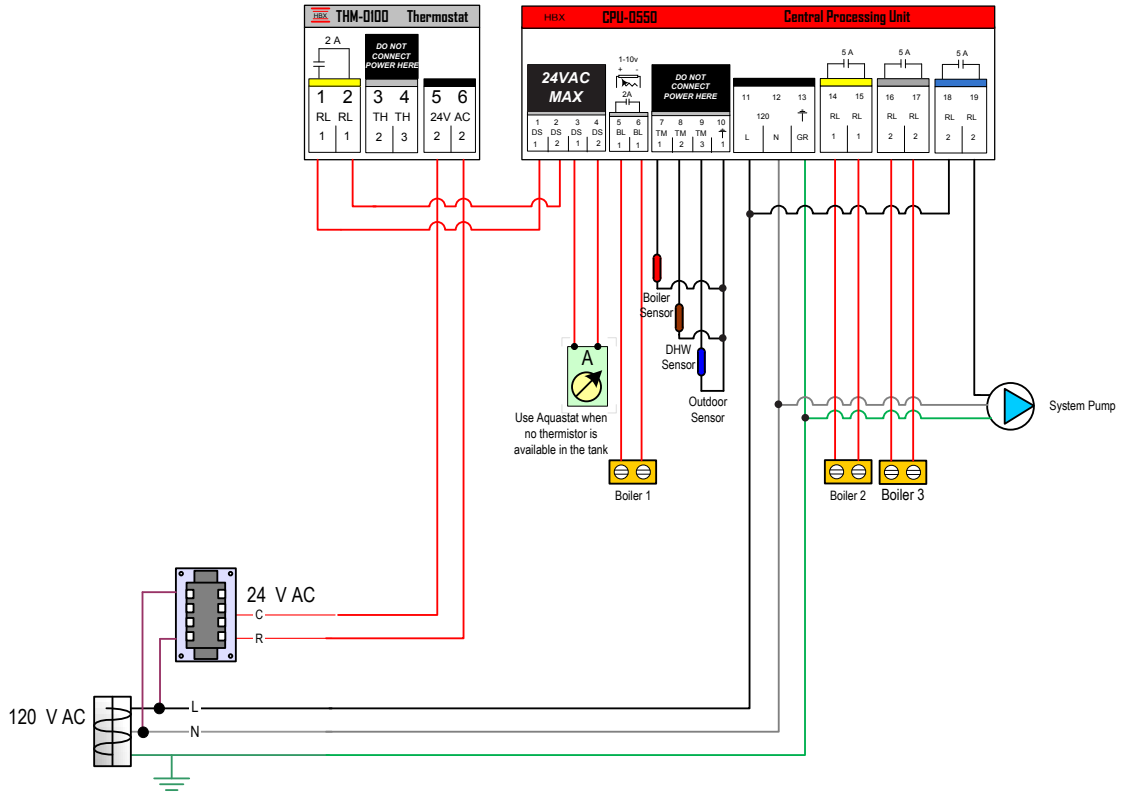

4) Single modulating boiler with DHW pump

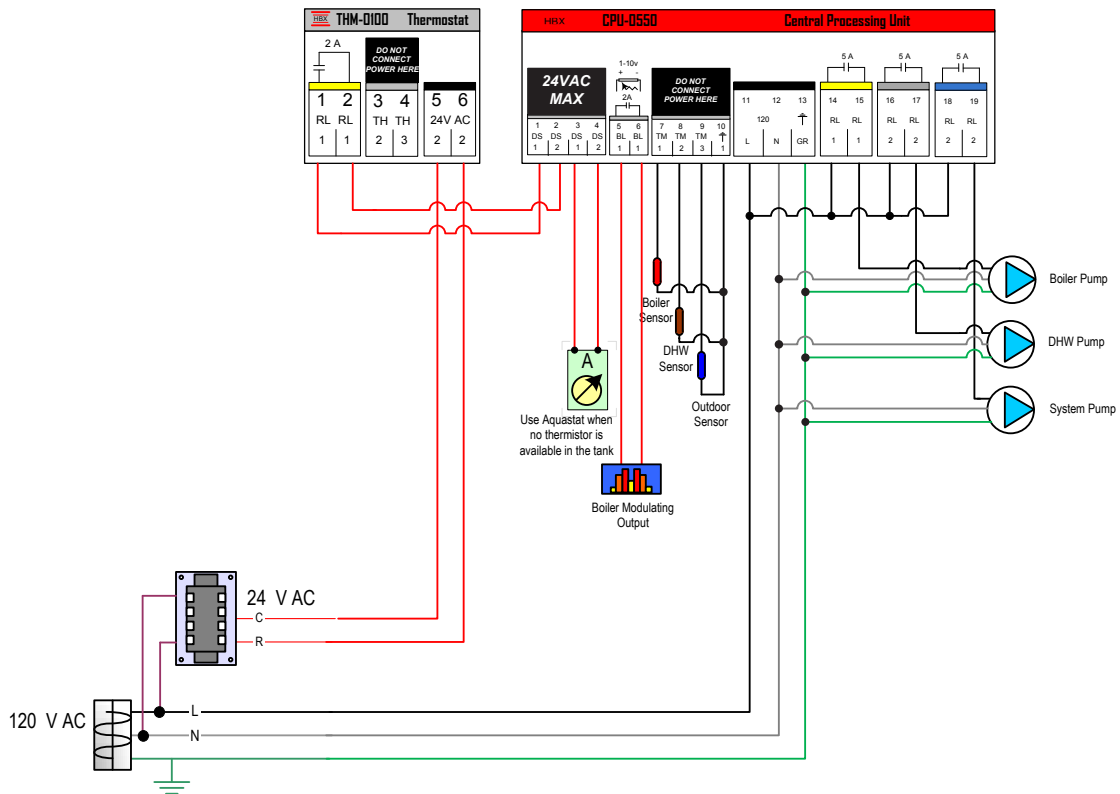

MIXING MODE WIRING DIAGRAMS

1) Single ON/OFF boiler with injection pump

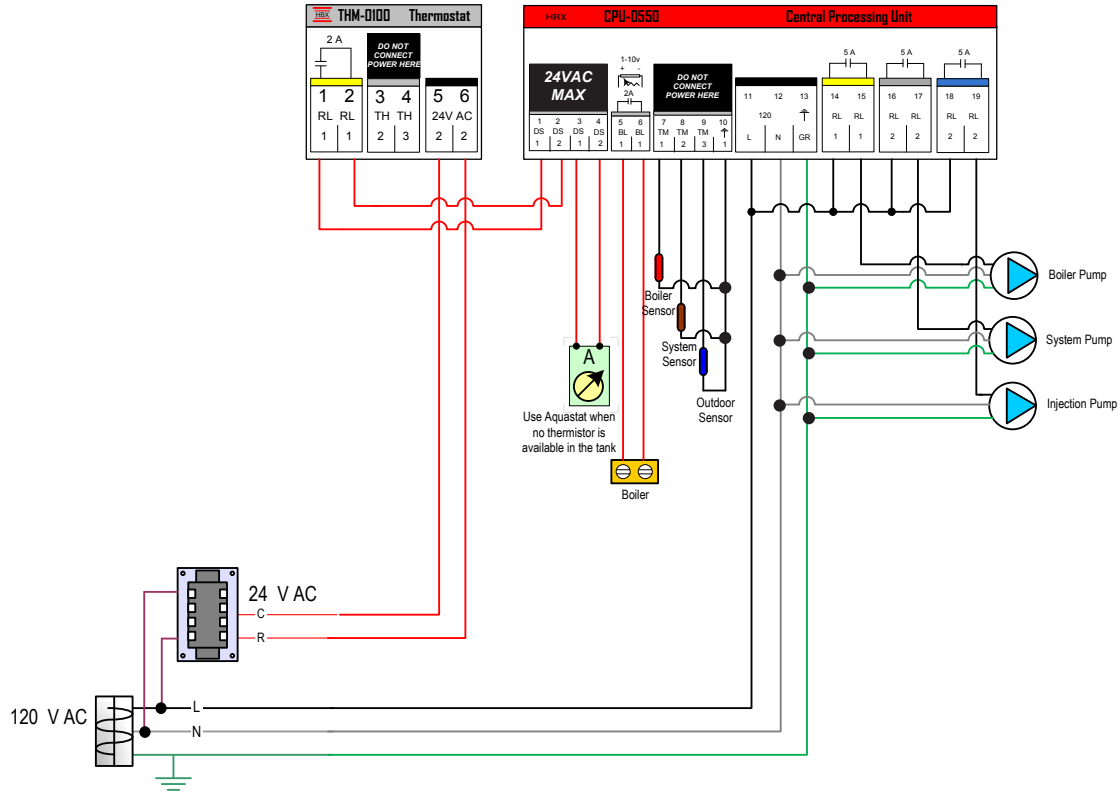

2) Single modulating boiler with injection pump

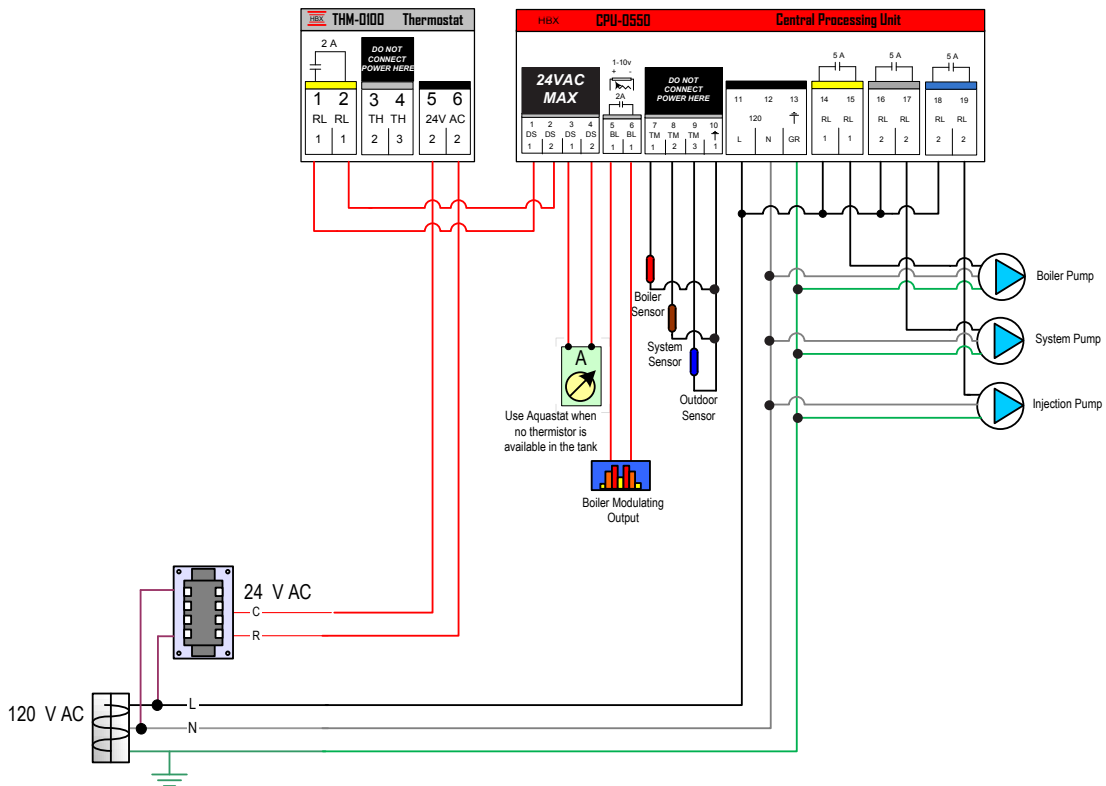

3) Single On/Off boiler with injection pump and DHW pump

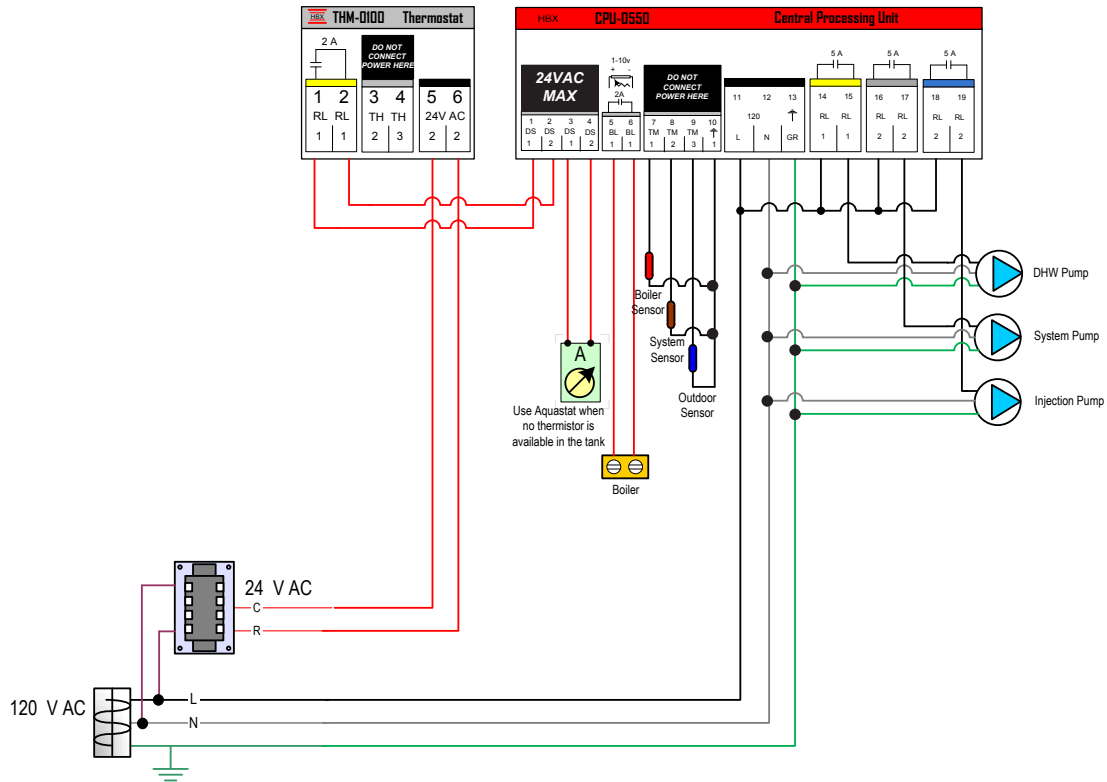

4) Single modulating boiler with injection pump and DHW pump

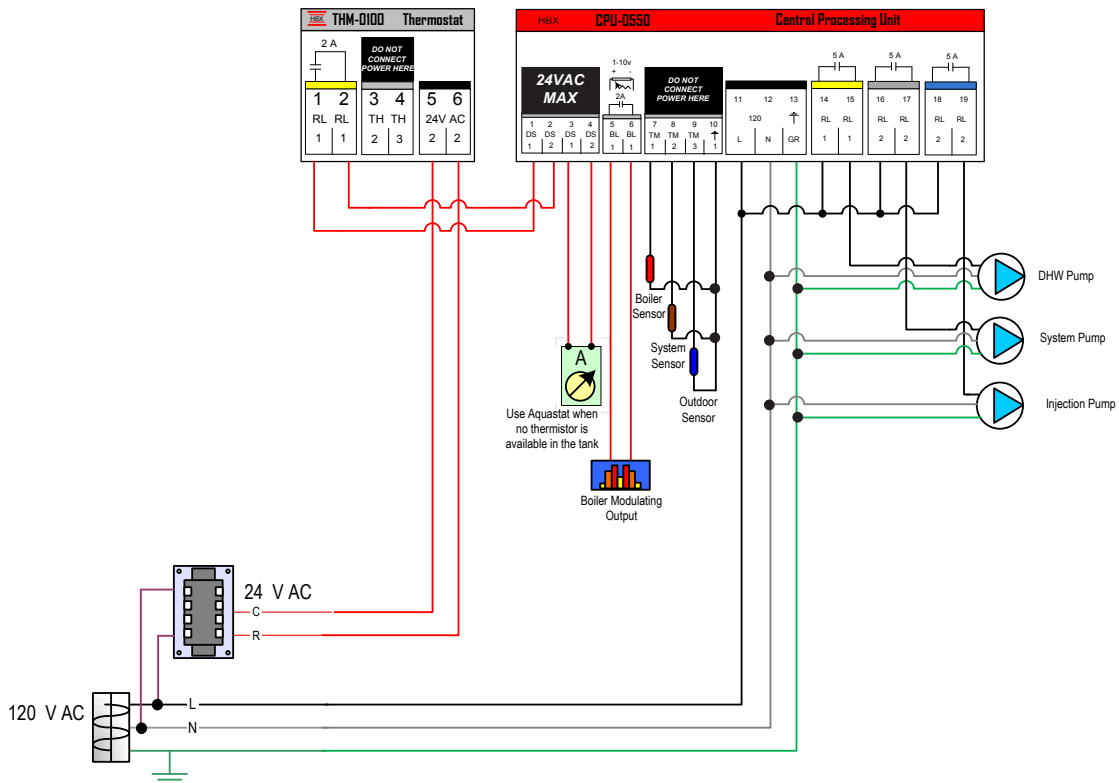

5) Two On/Off boilers with injection pump

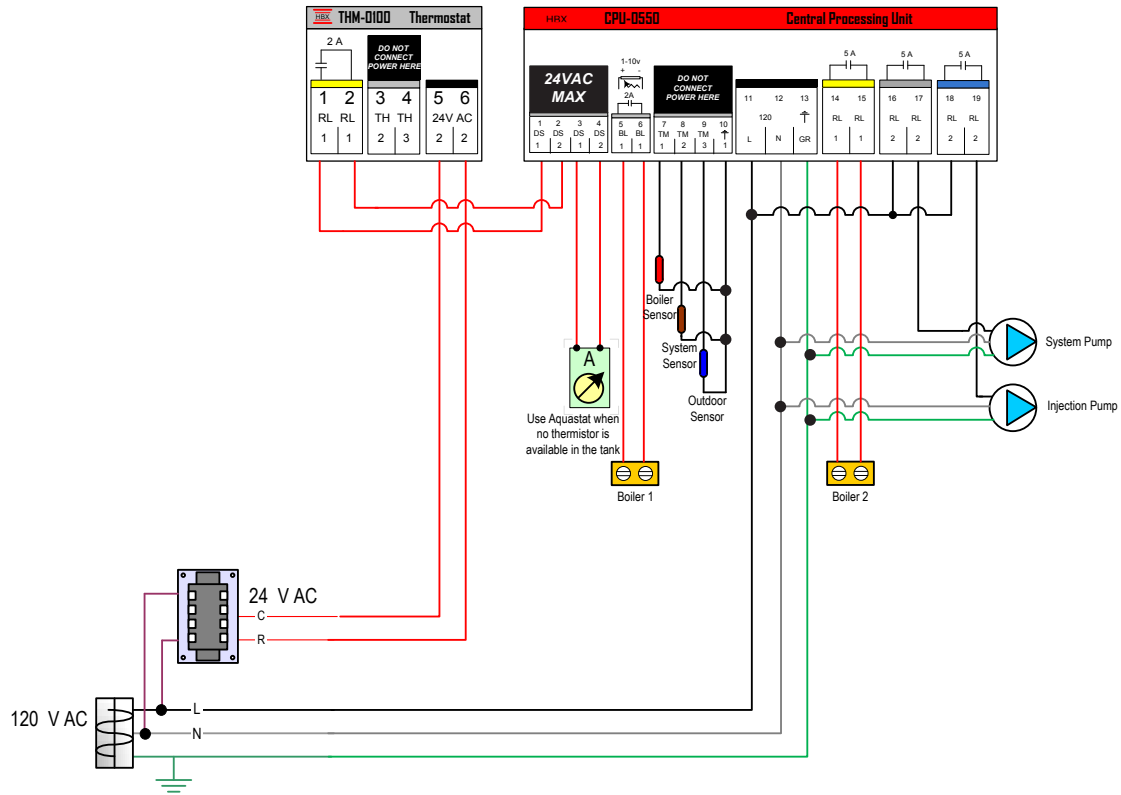

6) Single On/Off boiler with a floating action valve (power open/power close)

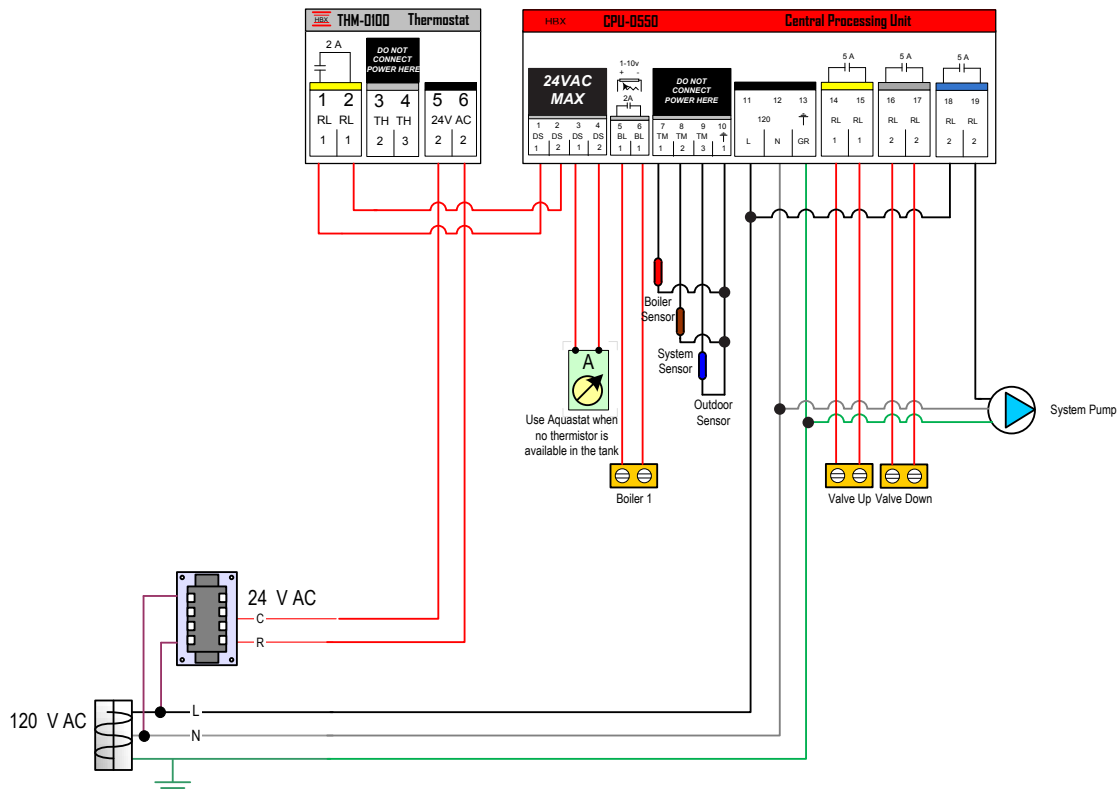

7) Single On/Off boiler with modulating valve output (1-10VDC)

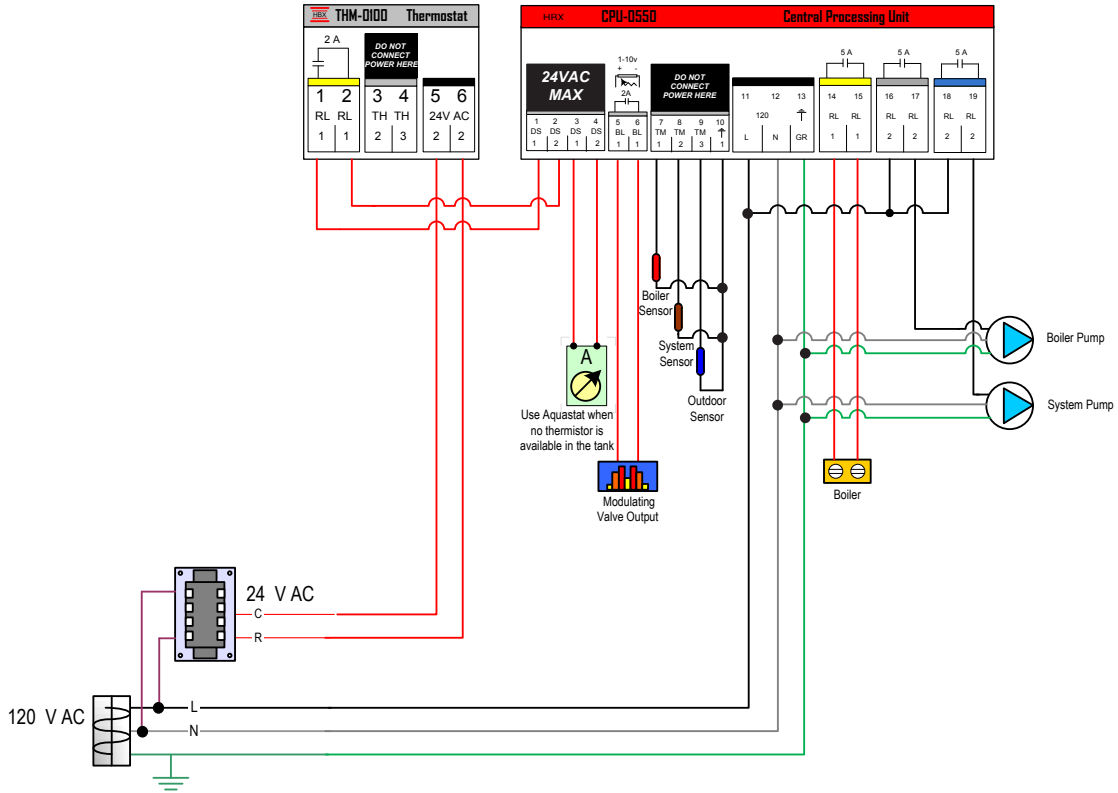

8) Single On/Off boiler with modulating valve output (1-10VDC) and DHW pump

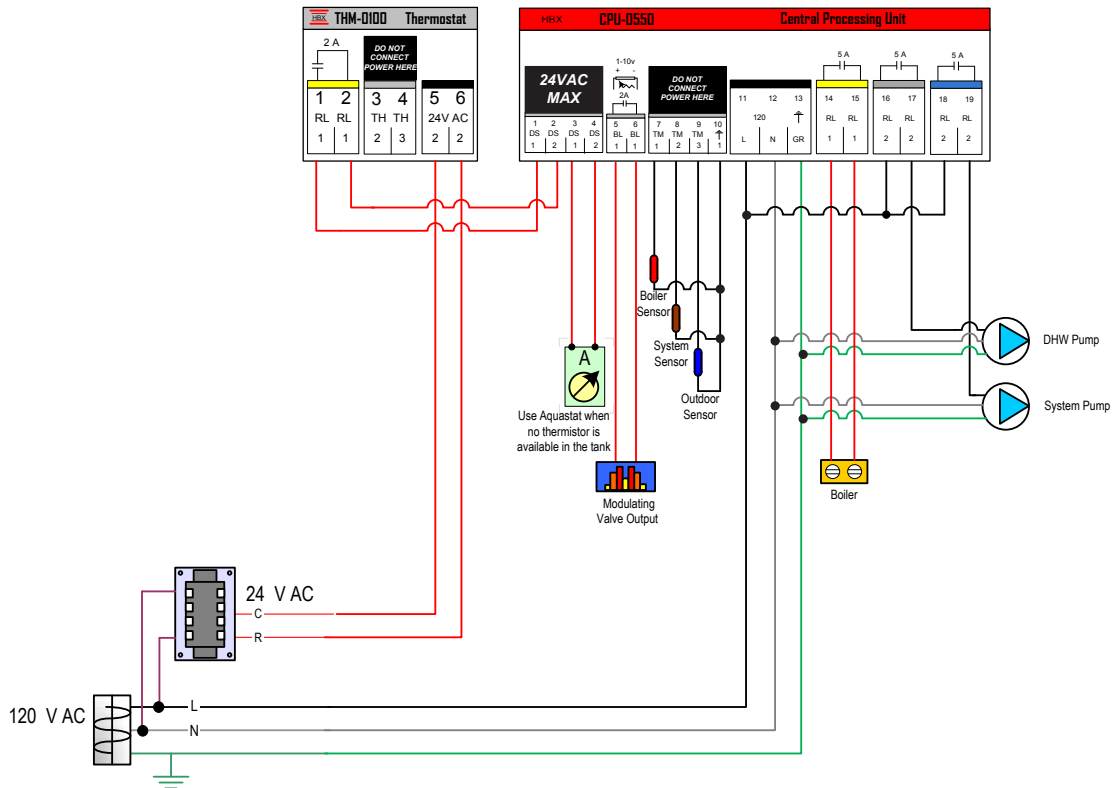

DIFFERENTIAL MODE WIRING DIAGRAM

1) Differential Setpoint

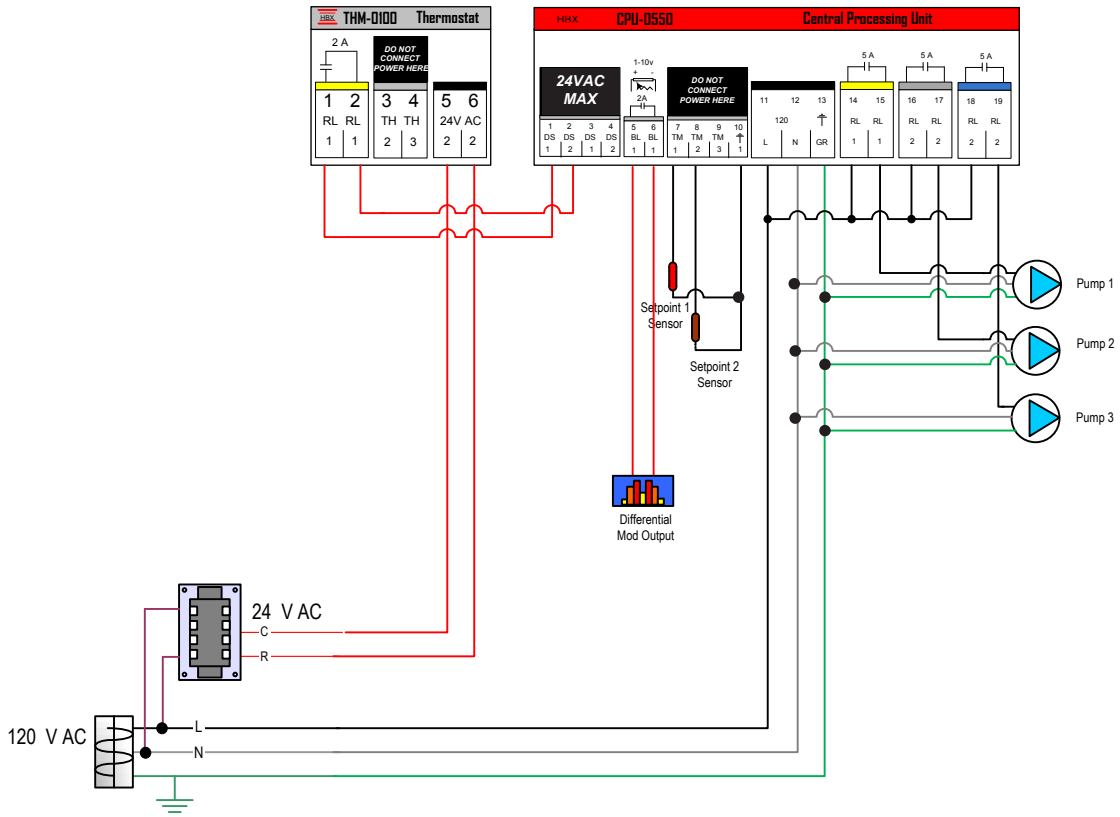

PUMP SEQUENCER MODE WIRING DIAGRAM

1) Pump Sequencer

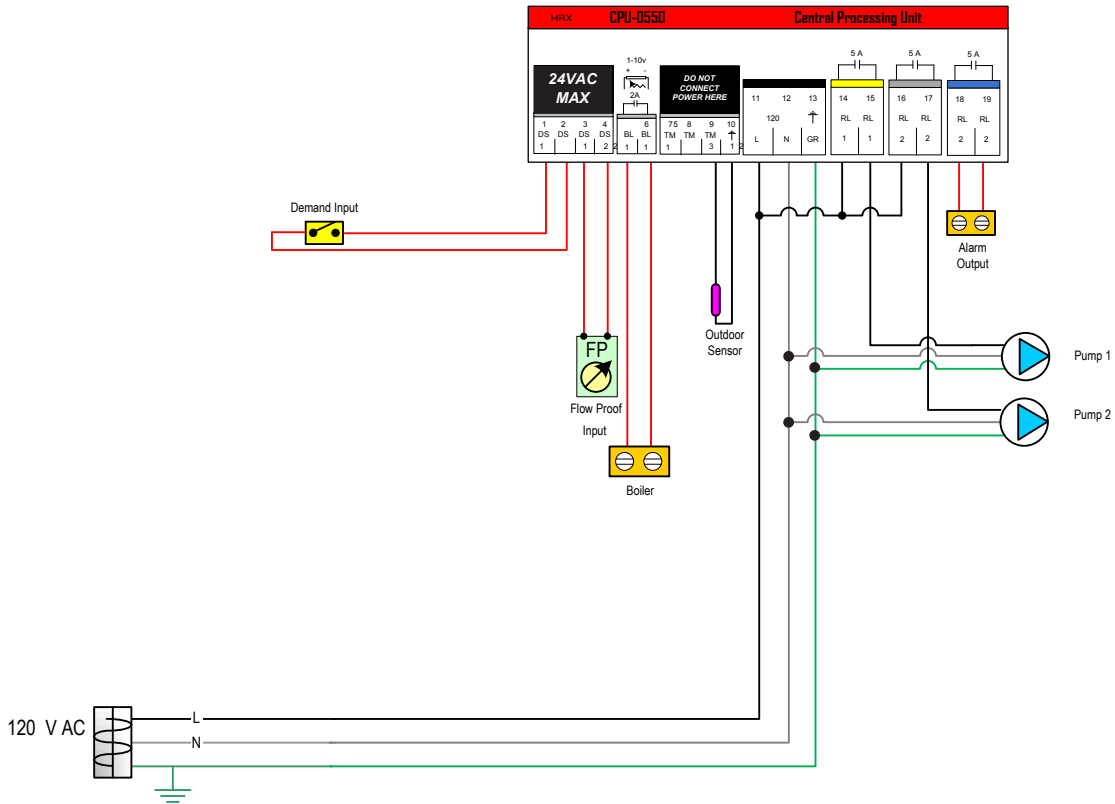

DUAL SETPOINT MODE WIRING DIAGRAM

1) Dual Setpoint

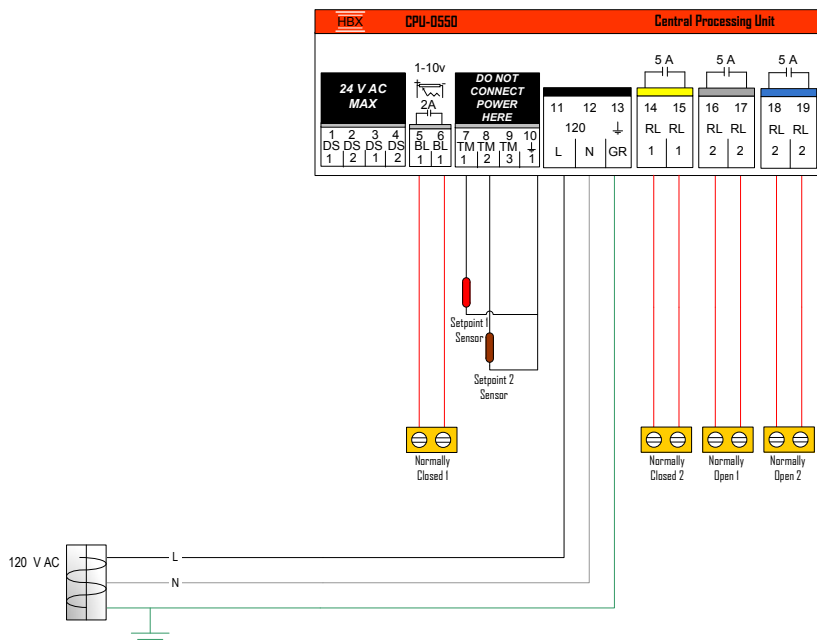

CPU-0550 TROUBLESHOOTING GUIDE

| ISSUE | POSSIBLE CAUSES & RESOLUTIONS |
|---|---|
| Control won't turn on boiler(s) | <ul style="list-style-type: none"> • Check if there is a demand on pins 1-2 and pins 3-4. • Check WWSD • Check heat demand settings (see page 20.) • Check wiring |
| When heating demand is already present and DHW demand given, control isn't raising temperature to DHW target | <ul style="list-style-type: none"> • Check DHW setup to turn "DHW Priority" to "Y" (see page 11.) |
| Boilers cycling too frequently | <ul style="list-style-type: none"> • Check boiler differential (see page 8.) • Check boiler lag time (see page 8.) |
| Abnormal boiler target | <ul style="list-style-type: none"> • Check outdoor reset settings (see page 10.) |
| No Heat demand is present | <ul style="list-style-type: none"> • Check if there is a demand on pins 1-2 and pins 3-4. • Check heat demand settings (see page 20.) |
| Control is in WWSD when outside temperature is below WWSD. | <ul style="list-style-type: none"> • Check that Outdoor sensor is connected on pins 9-10 • Check outdoor sensor placement. Outdoor sensor should not be in direct sunlight. |
| Boiler temperature showing error/dashes | <ul style="list-style-type: none"> • Check that Boiler sensor is connected on pins 7-10 |
| Outdoor temperature showing error/dashes | <ul style="list-style-type: none"> • Check that Outdoor sensor is connected on pins 9-10 |
| DHW temperature showing error/dashes | <ul style="list-style-type: none"> • Check that DHW sensor is connected on pins 8-10 (Only needed if no aquastat being used) |
| System pump is not turning on | <ul style="list-style-type: none"> • Check wiring • No heat demand present • Check heat demand settings (see page 20.) |
| Boiler Pump is not turning on | <ul style="list-style-type: none"> • Check wiring • No heat demand present • Check heat demand settings (see page 20.) |
| DHW Pump is not turning on | <ul style="list-style-type: none"> • Check wiring • No DHW demand present • Check heat demand settings (see page 20.) |
| Boilers are turning on at the same time | <ul style="list-style-type: none"> • Check Fast DHW setting and turn it to "N" (see page 11.) |

CPU-0550 TROUBLESHOOTING GUIDE - MIXING MODE

| ISSUE | POSSIBLE CAUSES & RESOLUTIONS |
|--|--|
| Mixing device (Injection, floating action, modulating valve) will not turn on | <ul style="list-style-type: none"> • Check wiring • Control is in boiler protection (see page 17.) |
| Control says mixing device on but device not powered | <ul style="list-style-type: none"> • Control does not use wet contacts, relays are dry contacts rated for 5A |
| System temperature fluctuating | <ul style="list-style-type: none"> • Check outdoor reset values (see page 17.) |
| Control won't turn on boiler(s) | <ul style="list-style-type: none"> • Check if there is a demand on pins 1-2 and pins 3-4. • Check WWS • Check heat demand settings (see page 20.) • Check wiring |
| System pump is not turning on | <ul style="list-style-type: none"> • Check wiring • No heat demand present • Check heat demand settings (see page 20.) |
| Boiler pump is not turning on | <ul style="list-style-type: none"> • Check wiring • No heat demand present • Check heat demand settings (see page 20.) |
| DHW Pump is not turning on | <ul style="list-style-type: none"> • Check wiring • No DHW demand present • Check heat demand settings (see page 20.) |
| System Temperature showing error/dashes | <ul style="list-style-type: none"> • Check that System sensor is connected on pins 8-10 |

CPU-0550 TROUBLESHOOTING GUIDE - DIFFERENTIAL SETPOINT MODE

| ISSUE | POSSIBLE CAUSES & RESOLUTIONS |
|---|--|
| Control won't turn on pumps | <ul style="list-style-type: none"> • Check if there is a demand on pins 1-2 • Check setpoint settings (see page 23.) |
| Setpoint temperatures showing error/dashes | <ul style="list-style-type: none"> • Check setpoint sensor wiring to pins 7-10 and 8-10 |

CPU-0550 TROUBLESHOOTING GUIDE - PUMP SEQUENCER MODE

| ISSUE | POSSIBLE CAUSES & RESOLUTIONS |
|---|--|
| Control won't turn on pumps | <ul style="list-style-type: none">• Check if there is a demand on pins 1-2 and flow proof input on pins 3-4• Check WWSO settings (see page 27.) |
| Screen is flashing orange | <ul style="list-style-type: none">• Flow proof has failed on one pump, control will attempt to engage second pump |
| Screen is flashing red | <ul style="list-style-type: none">• Flow proof has failed on both pumps, alarm relay is now engaged. |
| Pump(s) are running all the time | <ul style="list-style-type: none">• Check manual override settings (see page 26.) |
| Pump(s) are not sequencing | <ul style="list-style-type: none">• Check sequencing settings (see page 26.) |

CPU-0550 TROUBLESHOOTING GUIDE - DUAL SETPOINT MODE

| ISSUE | POSSIBLE CAUSES & RESOLUTIONS |
|--|--|
| Setpoint temperatures showing error/dashes | <ul style="list-style-type: none">• Check setpoint sensor wiring to pins 7-10 and 8-10 |
| Control says relays on but devices won't energize | <ul style="list-style-type: none">• Control does not use wet contacts, relays are dry contacts rated for 2A on relay 1 and 5A on relays 2, 3 & 4 |
| Setpoints Cycling too frequently | <ul style="list-style-type: none">• Check differential settings (see page 30.) |

Limited Warranty

HBX Controls warrants each of its products to be free from defects in workmanship and materials under normal use and service for a period of 24 months from date of manufacture or 12 months from date of purchase (with proof of purchase) from an HBX Authorized Dealer.

If the product proves to be defective within the applicable warranty period, HBX on its sole discretion will repair or replace said product. Replacement product may be new or refurbished of equivalent or better specifications, relative to the defective product. Replacement product need not be of identical design or model. Any repair or replacement product pursuant to this warranty shall be warranted for not less than 90 days from date of such repair, irrespective of any earlier expiration of original warranty period. When HBX provides replacement, the defective product becomes the property of HBX Controls.

Warranty Service, within the applicable warranty period, may be obtained by contacting HBX Technical Support for a Ticket number then submitting an RMA approval form to be issued an RMA number.

After an RMA number has been issued, the defective product must be packaged securely in the original or other suitable shipping package to ensure that it will not be damaged in transit. The RMA number must be visible on the outside of the package and a copy included inside the package. The package must be mailed or otherwise shipped back within 90 days to HBX with all costs of mailing/shipping/insurance prepaid by the warranty claimant.

Any package/s returned to HBX without an approved and visible RMA number can be rejected and shipped back to purchaser at purchaser's expense. HBX reserves the right, if deemed necessary, to charge a reasonable levy for costs incurred, additional to mailing or shipping costs.

Limitation of Warranties

If the HBX product does not operate as warranted above the purchasers sole remedy shall be, at HBX's option, repair or replacement. The foregoing warranties and remedies are exclusive and in lieu of all other warranties, expressed or implied, either in fact or by operation of law, statutory or otherwise, including warranties of merchantability and fitness for a particular purpose/application. HBX neither assumes nor authorizes any other person to assume for it any other liability in connection with the sale, installation maintenance or use of HBX Controls products.

HBX shall not be liable under this warranty; if its testing and examination discloses that the alleged defect in the product does not exist or was caused by the purchasers or third persons misuse, neglect, improper installation or testing, unauthorized attempts to repair or any other cause beyond the range of intended use, or by accident, fire, lightning or other hazard.

Limitation of Liability

In no event will HBX be liable for any damages, including loss of data, loss of profits, costs of cover or other incidental, consequential or indirect damages arising out of the installation, maintenance, commissioning, performance, failure or interruption of an HBX product, however caused and on any theory of liability. This limitation will apply even if HBX has been advised of the possibility of such damage.

Local Law

This limited warranty statement gives the purchaser specific legal rights. The purchaser may also have other rights which vary from state to state in the United States, from Province to Province in Canada and from Country to Country elsewhere in the world.

To the extent this Limited Warranty Statement is inconsistent with local law, this statement shall be deemed modified to be consistent with such local law. Under such local law, certain disclaimers and limitations of this statement may not apply to the purchaser. For example, some states in the United States, as well as some governments outside the United States (including Canadian Provinces), may:

Preclude the disclaimers and limitations in this statement from limiting the statutory rights of a consumer (e.g. United Kingdom);

Otherwise restrict the ability of a manufacturer to enforce such disclaimers or limitations; or Grant the purchaser additional warranty rights which the manufacturer cannot disclaim, or not allow limitations on the duration of implied warranties.

Phone: +1 (403) 720-0029 Fax: +1 (403) 720-0054
Email: info@hbxcontrols.com Web: www.hbxcontrols.com

Toll Free Technical Support: +1 (855) 410 2341

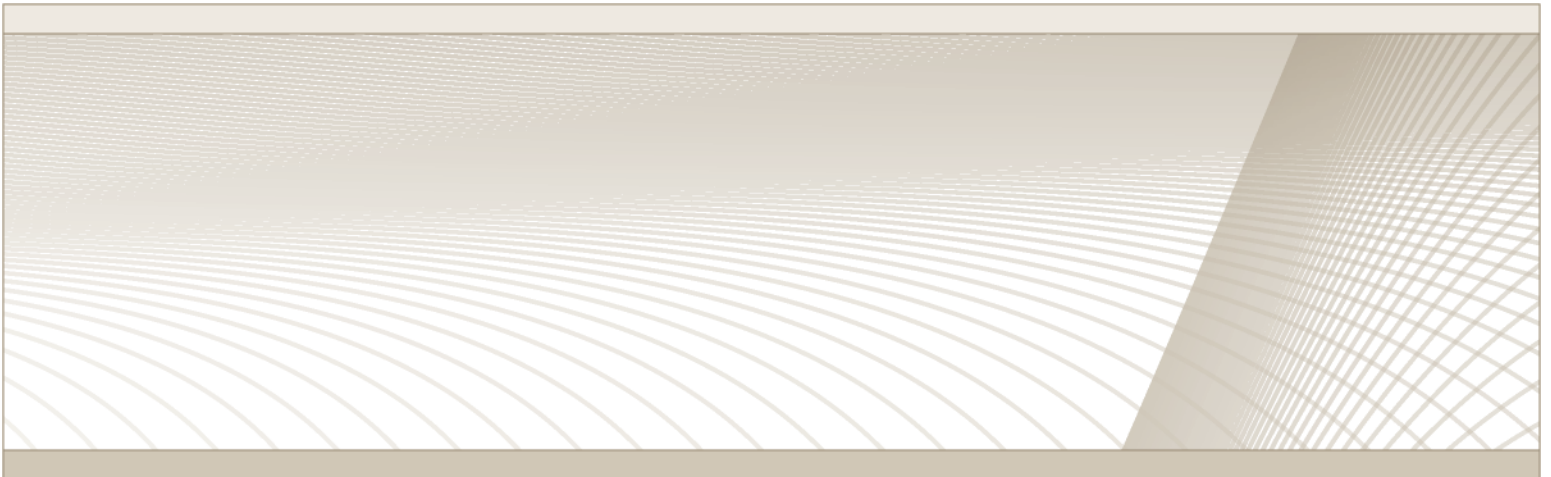

HBX Control Systems Inc.
4516 - 112th Avenue SE
Calgary, AB Canada T2C 2K2

© HBX Control Systems Inc. 2020